



THE CEREALOGIST

NO. 10 AUTUMN 1993

• THE JOURNAL FOR CROP CIRCLE STUDIES •

PRICE £2.40 / \$6.00



CONTENTS

Editorial Notes

Cerealogy under siege.
Disenchantment in 1993.
The good news.

Crop Circles in Canada, 1992

Chad Deetken

The Works of the Devil

George Wingfield

A View from Across the Pond

Paula Louis

Circles Review of 1993

James Chapman
and
Peter Sorensen

The Bluffer's Bluff is Called

Lucy Pringle

Reports and Sketches

From Sweden, from New York State,
from New Zealand, and a report on
Erik Beckjord's "Operation Magpie".

Moving in the Very Best Circles

Lois Horowitz

Book Review

Michael Glickman reviews
"The Only Planet of Choice"

New Swirled Order

Michael Glickman

Letters

Glastonbury Symposium

Ray Cox

We have not failed ...

John Haddington

EDITORIAL NOTES

Under siege

MORE THAN AT any time since the circles first came to public attention, the subject and its followers are under siege. One gets the impression that the sceptics and the circlefakers (most often the same people), the logical positivists, and others who call themselves "scientists", have rallied to stamp out and dismiss this disrespectful and unpredictable phenomenon which has caused such anguish to those of an orthodox disposition. If this founding known as "cerealogy" refuses to conform to conventional thinking, it cannot be allowed to live.

Whether the original elusive phenomenon, which so held public attention just three years ago, continues unabated or not is another matter. Several of us who have flown over the fields of Wiltshire and other counties this year have looked down in dismay at crop formations which bear little comparison with the circles of earlier years. The inescapable conclusion is, of course, that much of what we have seen in 1993 is manmade, and poorly manmade at that, although there are a few fine formations. What has become of the circlemakers of just a few years ago?

Disenchantment

Disenchantment in 1993 was often such that seasoned circles researchers did not bother to go and examine many of the new formations. Some pictograms near Devizes and near Warminster were of such indifferent quality that they would have barely scored in the 1992 Wycombe competition. Has the mythical "A-team" which two years ago supposedly produced the magnificent Wiltshire pictograms disbanded? (Or are we justified in thinking that "A-team" is merely the sceptic's euphemism for the genuine phenomenon?)

They will, of course, argue that in earlier years we deceived ourselves such was enthusiasm and receptiveness. There is some truth here but one has only to look at the aerial photographs of many of the circles of 1987 through to 1991 to realise that there was a perfection then which is only seldom seen today. Many Wiltshire pictograms of 1990 and 1991 displayed a quite breathtaking artistry and proportion, only very occasionally apparent now.

What can this mean? There is little doubt that for the past two years, in England at any rate, the genuine phenomenon has been swamped and heavily obscured

by a profusion of manmade hoaxes. The proportion of these has risen sharply ever since the circles received massive media attention in 1990. And inconclusive results of scientific testing, while clearly indicating some effects of a highly unusual nature, have given no firm method of distinguishing the genuine article.

Although the circles may have declined in Britain, there have been outbreaks of the phenomenon in other countries in the past two seasons which have affected people in entirely similar ways. The latest of these have been in Hungary and Sweden, not to mention the on-going saga of the Canadian circles. *The Cerealogist* will continue to bring you reports on circles activity from these countries and others.

Communique II

A further blow to the circles community will shortly be dealt when John Macnish's forthcoming *Cropcircle Communique II* is shown on TV. This time the producer has strongly followed the line that the circles are all, or at least 80%, faked and to prove this contention he has shot nocturnal footage of people, such as Doug & Dave, and Schnabel faking circles. Without disputing the thesis that much of what we have seen recently is manmade, one could maintain that this sort of "documentary solution" is merely another case of sceptics manufacturing their own truth.

It is similar to the tactic, used by some of the "CREEP" group this summer, of floating balloons daubed with green luminescent paint across fields near Alton Barnes to deceive cropwatchers and skywatchers into thinking these were UFOs. Set up the researchers, deceive them, then discredit them. "Therefore", the sceptics can then say, "any previously reported UFO sightings by these people are fallacious. Q.E.D." What a thoroughly dishonest approach this is!

When Richard Andrews wrote to John Macnish earlier this year to say that he believed the Hyden Hill, East Meon, pictogram of July 1992 was a fake, he received a reply (dated May 30th) saying "If East Meon is a hoax --how do we know this? All I have heard so far is various rumours...." Well, actually, John, you *should* know because you commissioned Doug & Dave to make it (with the farmer's permission). There's not much point in trying to pull the wool over people's eyes once you've been rumbled! What does all this say about *Communique II*?

Good news.

The good news amidst all this doubt, cynicism and deception is that there remains a strong band of circles researchers and enthusiasts who are undeterred. Research goes on and the fellowship of the circles, so apparent at the continuing conferences, thrives. Experience has shown many of us that something of a quite extraordinary nature lies behind the circles phenomenon and its pursuit has opened up many doors and given new unexpected insights.

However, one lesson is that again and again preconceived ideas and theories may have to be discarded in the light of events. Paula Louis, in this issue, suggests even the manmade formations should be considered a significant part of the phenomenon. Many will resist this, but that possibility may explain our choice of cover photo.

Front cover: *True or false? A magnificent Mandala pictogram, near Bythorn, found Sept 2nd. 'Wonderful' and 'powerful' were comments heard. But we acknowledge it was manmade and we know who made it.*



THE CEREALOGIST
Number Ten. Autumn 1993
ISSN 0961-6942

Editor George Wingfield
Assistant Editor John Haddington

Design & Typeset George Wingfield
Editorial Consultant Michael Glickman
Printed Embassy Press

Subscriptions & Distribution Hugh Pincott
Conference Organiser Deborah Hall

Published Hearne House, North Wootton,
Shepton Mallet, Somerset BA4 4HW.
Tel/Fax : 0749 - 890257

The Cerealogist is published thrice yearly.
Advertising rates can be obtained on
application to the above address.

Single copy £2.50.
One year's Subscription £7.50 inc. p&p.
Cheques or postal orders made payable to
The Cerealogist are to be sent to Specialist
Knowledge Services, St Aldhelm, 20 Paul
Street, Frome, Somerset BA11 1DX. Tel/
Fax: 0373 - 451777.

CROP CIRCLES IN CANADA, 1992

Chad Deetken tells us of his investigations into the 1992 circles in Saskatchewan.

SINCE THE SPRING of 1990 when I first began investigating crop circles, Canadian farm fields have yielded about one to two dozen circle sites per year. Many were noteworthy for having peculiar features but their shapes were usually uncomplicated, especially when compared to their British cousins. Formations ranged from plain circles to a unique 200 foot event consisting of seven circles joined by paths in Lethbridge, Alberta in 1991. The majority however, could be described as unimpressive.

In 1992 a total of 13 sites were logged containing 31 individual unattached circles. For most of the summer there was nothing to indicate anything unusual was in the making. But then on August 22nd, something happened which opened a new chapter in cereology.

Day of the porcupine

In the last days of August 1992, near the village of Milestone, Saskatchewan, farmer Joe Rennick discovered an unusual flattened area measuring 22' by 63' in his wheat field. It was an irregular shape, three circles overlapping each other much like the pattern of a stone skipping on water. Never having seen a crop circle before, Mr Rennick initially thought he was looking at an odd pattern of wind damage. But then he noticed there was a counterclockwise direction to the fallen stalks. With a heightened sense of curiosity, he walked into the formation and there, to his amazement, lay the body of a very dead and very flat porcupine.

Closer examination of this oddity revealed no evidence of wounds or physical damage but it was obvious to him this unfortunate creature was either crushed by a heavy

weight or encountered some powerful force. Likewise strange, though he estimated the porcupine had been dead for about a week, there was no bad odour or evidence of decomposition.

A mature porcupine weighs well over 25 lbs and stands more than 12 inches tall. This one had been flattened to a thickness of about two inches, its legs spread out underneath it in the form of an "X" like a cartoon character. Furthermore, a skid mark in the soil embedded with bits of broken quills indicated it had encountered something at the edge of the formation which dragged into the centre. The quills on its body were aligned in the same direction as the swirl of the wheat.

Researchers had always been curious as to why no dead or maimed animals were ever found in crop circles. If the energy responsible for creating these patterns is so powerful that it can flatten stalks in very large areas, how could it be that animals were not affected? Surely the occasional creature would find itself in the wrong place at the wrong time.

The answer may lie in the possibility that there is some sort of indication of danger prior to a crop circle being formed.

While most animals will scurry or fly away, a porcupine when faced with danger stands its ground and rolls itself into a ball relying on its sharp quills for defence.

Mr Rennick also noted that while the soil in the field was very muddy and sticky, the soil in the formation was dry and hard as cement. The imprints of fallen stalks were clearly visible as though the stalks had been forcefully slammed into the ground before it hardened. Also, the plants in the field were still green and subtle while in the formation they were dry and brittle, the seeds shrivelled like prunes.

The unfortunate thing about this case is that no tests could be done on the body of the dead porcupine. Mr Rennick had disposed of the carcass when it finally started to decompose which was before he phoned me about it. All the facts, however, were verified by four different witnesses.

On speaking to him again on November 17th, he mentioned that there had been an addition in the shape of a horseshoe which had attached itself to one end of the original formation on November 12th.

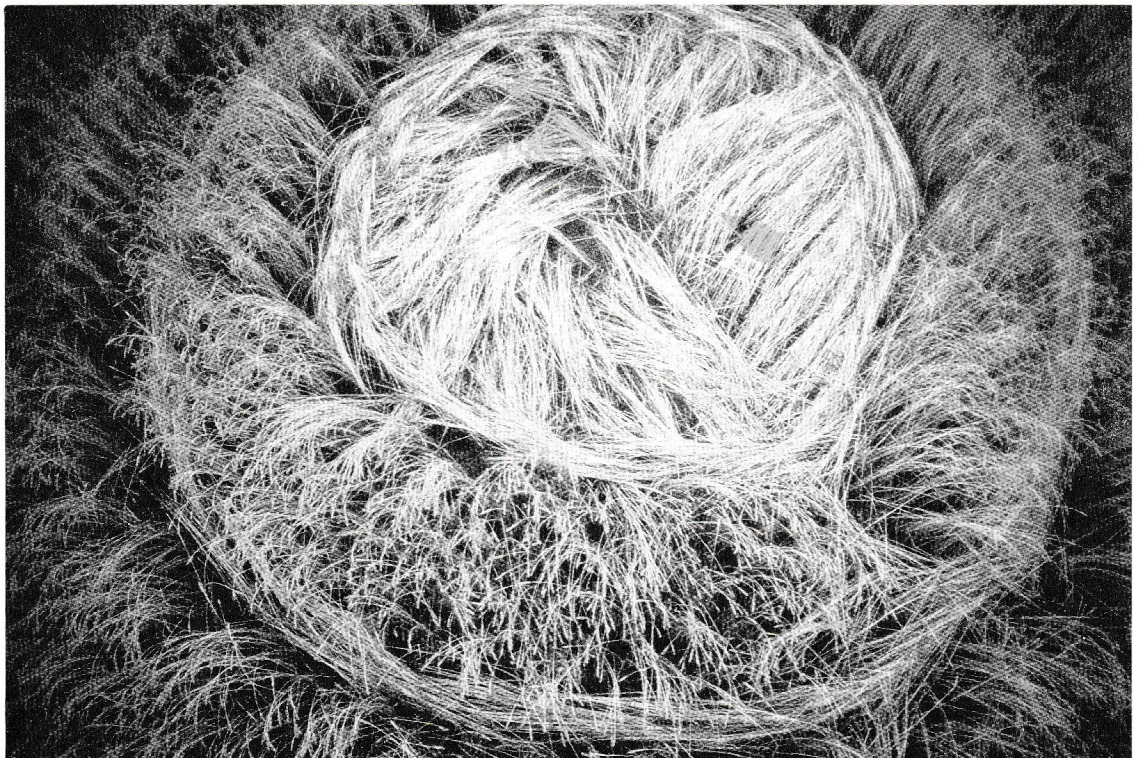

The very intricately laid ringed circle in wheat at Albertville, Saskatchewan.

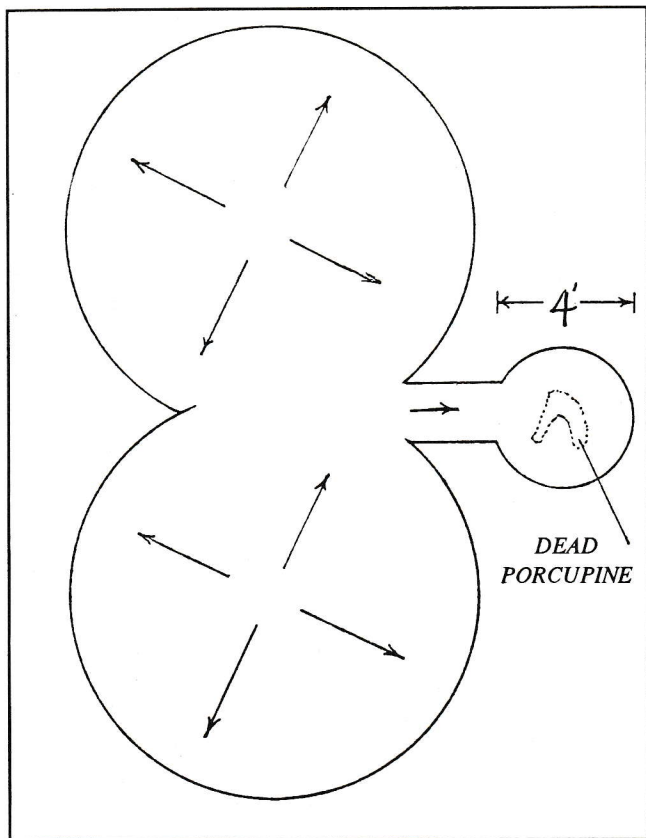
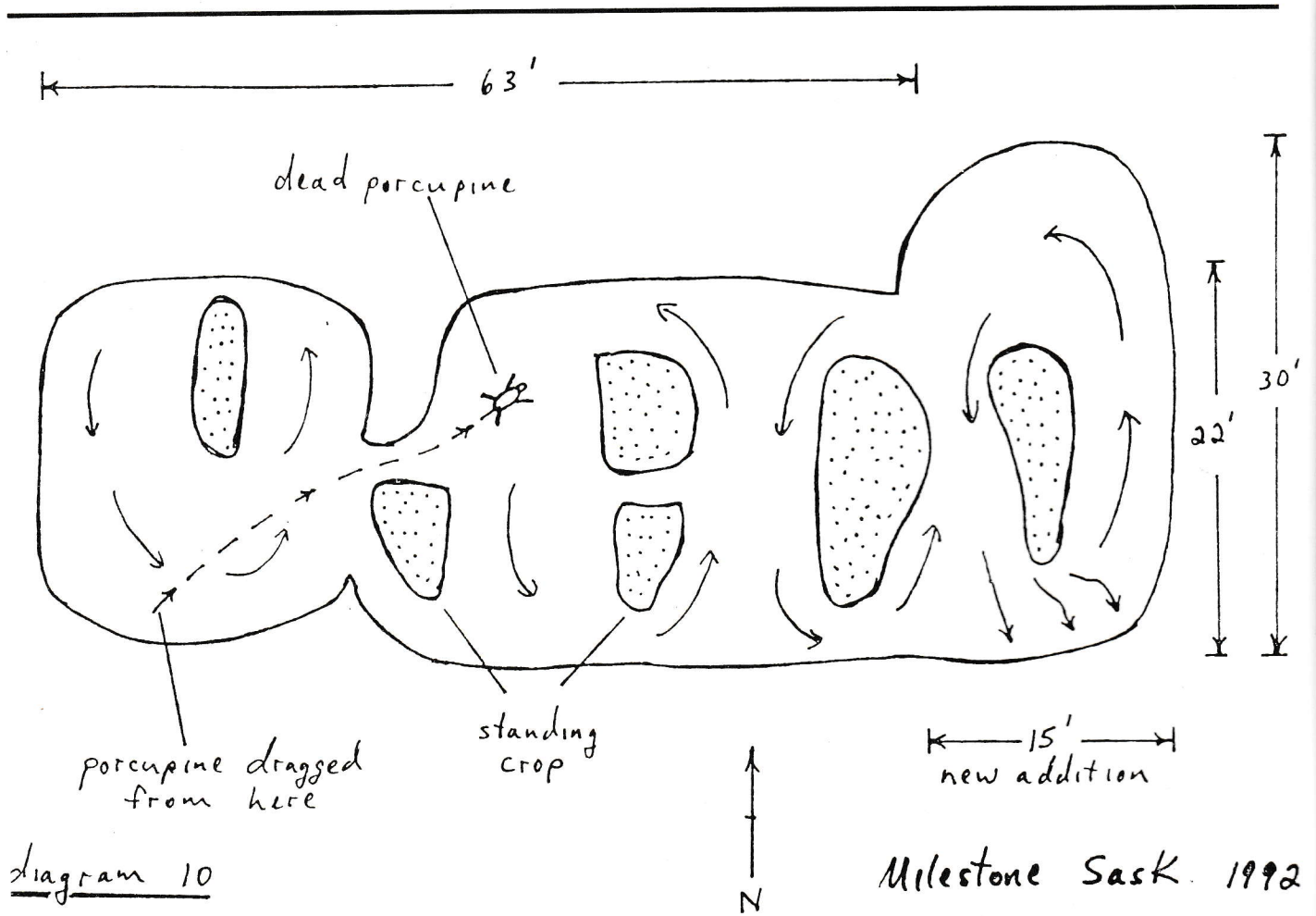

Crop formation at Estevan, Saskatchewan, showing position of dead porcupine, found in August 1989.

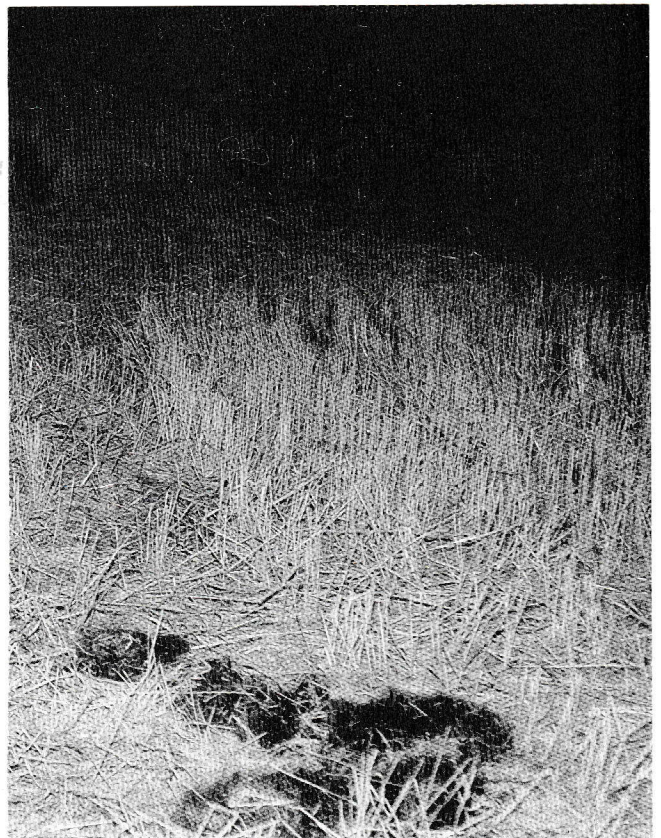

R.C.M.P. photograph of blackened remains of porcupine at Estevan circles.

Another Prickly Question

While the tale of the unfortunate porcupine was around in the Milestone area, a second incident was brought to light. In mid August, 1989 in Estevan Saskatchewan, 100 miles SE of Milestone, farmer Don Hagel discovered two 12' circles in his wheat field. The circles, both of which displayed a radial lay, touched each other like a "figure 8". At the point where they touched, a short path led to a 4' circle. In this small circle lay the remains of a porcupine.

After returning home to get his wife, the two surmised that the animal had been dead over two weeks. All that remained were quills and bones. The flesh and skin had completely disappeared and part of the jaw and all the tail bones were missing. The remains were very black as if they were covered in soot although it did not rub off when handled. Also, the ground it laid on was not blackened. Both had lived on farms all their lives and swear neither predators nor ants could account for the remains they saw. Besides, only a mad coyote or masochistic dog would tangle with a porcupine. They have virtually no enemies.

Never having heard of crop circles before, the Hagels, suspecting foul play, called the police. After investigating at some length, the police filed a report stating the evidence pointed to this having been the site of a Satanic ritual though no such case had ever been reported before (or since). The area was photographed and tissue samples sent to a lab for analysis. Because of the suspicions of Satanism, the lab was instructed to look only for signs of burning, as from a fire. The results were negative and no other tests were ever done.

To run and live another day

A third case with a porcupine connection was reported by farmers Lyle and Shirley Van Buskirt of Kyle, Saskatchewan. A 12' circle in wheat was found near their house in mid August, 1992. It was the shape of a "doughnut", sporting a 3 ft 6 in. centre of standing crop. In that centre was "a large amount" of porcupine droppings. It is possible the location of the droppings are coincidental. However, it is conceivable that this porcupine, after receiving the fright of its life, escaped serious injury because it was lucky enough to be in the unaffected centre when the circle was formed. Or, God knows, the circle makers may have spared the creature by leaving the centre unaffected.

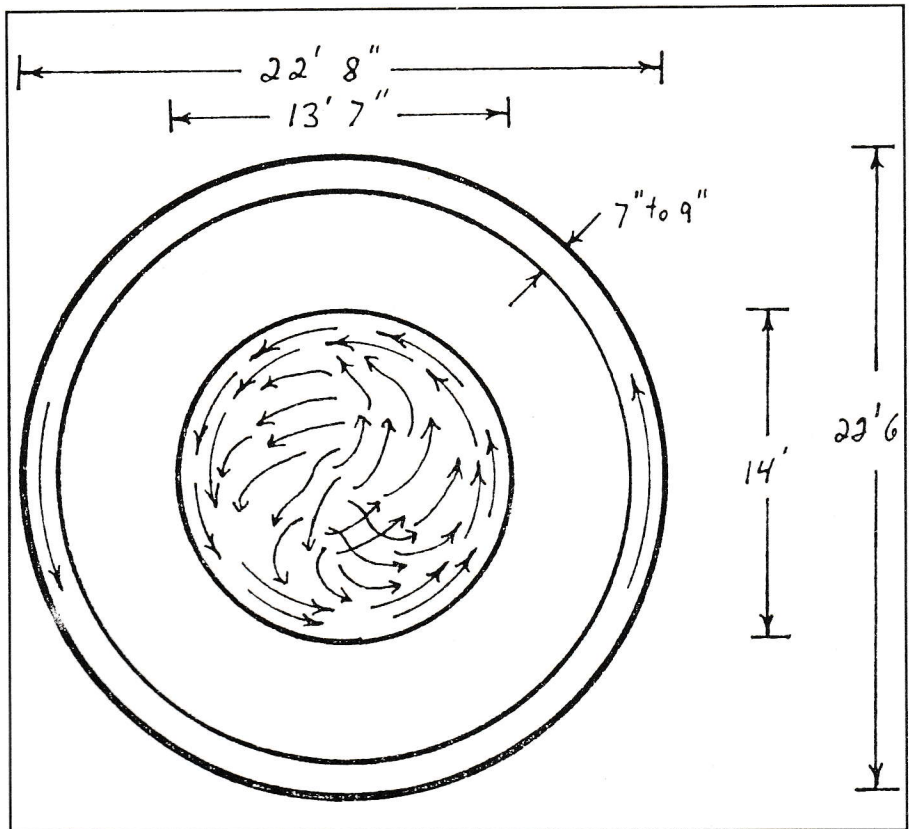

Diagram of the second ringed circle found at Albertville, September 1992. A photograph of this circle is shown on page 3.

Back To normal

Although there were other formations of interest such as the four in Manitoba shaped like the symbol for Mars and a rough circle in a field of corn (maize) in Ontario, I will list only a few others which I personally investigated and thought significant.

The first of these was a ringed circle found by Ed Beauchesne on his farm near Albertville, Saskatchewan. This formation in oats was created on September 21/22 and was discovered on September 23rd. The ring was almost perfectly round, measuring 35' 10" across. The circle varied from 17' 8" diameter to 15' 9". The swirl in both was counterclockwise.

The interesting aspect of this formation was that the axis was completely off centre. The distance from the swirl centre to the edge of the circle was 11 feet while to the opposite edge, 6' 8". Also, the width of the ring varied from 27" on its "heavy" side to only 15" on the opposite side. If this formation could have been spun on its axis, it would have had a severe wobble. By what mechanism could this pattern have possibly been made?

The second formation was also a circle with a ring about a mile down the road from the first one. It was in wheat and its

ring measured 22' 8", the circle 14'. Both were almost perfectly round. The swirl also lay counterclockwise. The importance of this one was that it formed only hours before my arrival at the farm.

Mr Beauchesne was positive it was not there the night before because he had passed by in the evening to inspect his crop. He discovered it while driving by next morning, shortly before my arrival. He didn't tell anyone about it nor did he enter it. In fact, he remained in sight of it until I arrived.

We have never had a case of suspected hoaxing or even claims of hoaxing in Canada but I had always hoped for a chance to test for signs of this possibility. This meant finding a formation which no one had entered. At last I had the opportunity.

Because Canadian fields do not have tram lines as they do in England, I carefully searched for signs of entry between the road and the formation. There was not the slightest evidence. Then, starting at the edge of the ring, I spent the next 8 hours crawling on my hands and knees looking for clues.

Footprints, depressions in the soil, stalks bent at points other than at the ground level, broken stalks which were out of place or which lay pressed closer to the ground than the rest, nothing escaped my

attention. After covering nearly every square inch of the formation, I was satisfied that there was absolutely no sign of human or other activity in or near this crop circle. This was most comforting.

Only a few weeks earlier I was in England working on Project Argus during which time my fellow researchers and myself were subjected to intolerable harassment by a few sociopaths intent on disrupting serious research. They supposedly hoaxed some formations but mostly created an atmosphere of anxiety and uncertainty by spreading rumours of mass hoaxing. Some people were beginning to have doubts about the phenomenon. The astounding data collected over the past 10 years was becoming blurred. But now, once again, there was reassuring evidence that hoaxing could not possibly account for all circles. The cause is still a mystery.

Off with their heads

The last incident I will mention occurred on the farm of Stan Squires some miles from Milestone, Saskatchewan in mid September. While Mr Squires was harvesting his crop of wheat, he noticed two round depressions ahead of his combine. He stopped the machine and on closer inspection noted two circles, each 15' in diameter. The stalks were still standing but had been cut about 10 to 12" above the ground. Although he searched carefully, he found no trace of the severed tops. It was as if a large lawnmower had been lowered from above, slicing off the stalks and sucking them up.

Germination tests

The following graphs represent the results of germination tests I carried out on seeds from the Milestone and Albertville formations. The Milestone samples were done in sterile soil involving 30 seeds per group. The Albertville samples were done on germination paper and involved 50 seeds per group. The results are similar to tests done by Dr W C Levengood in Michigan.

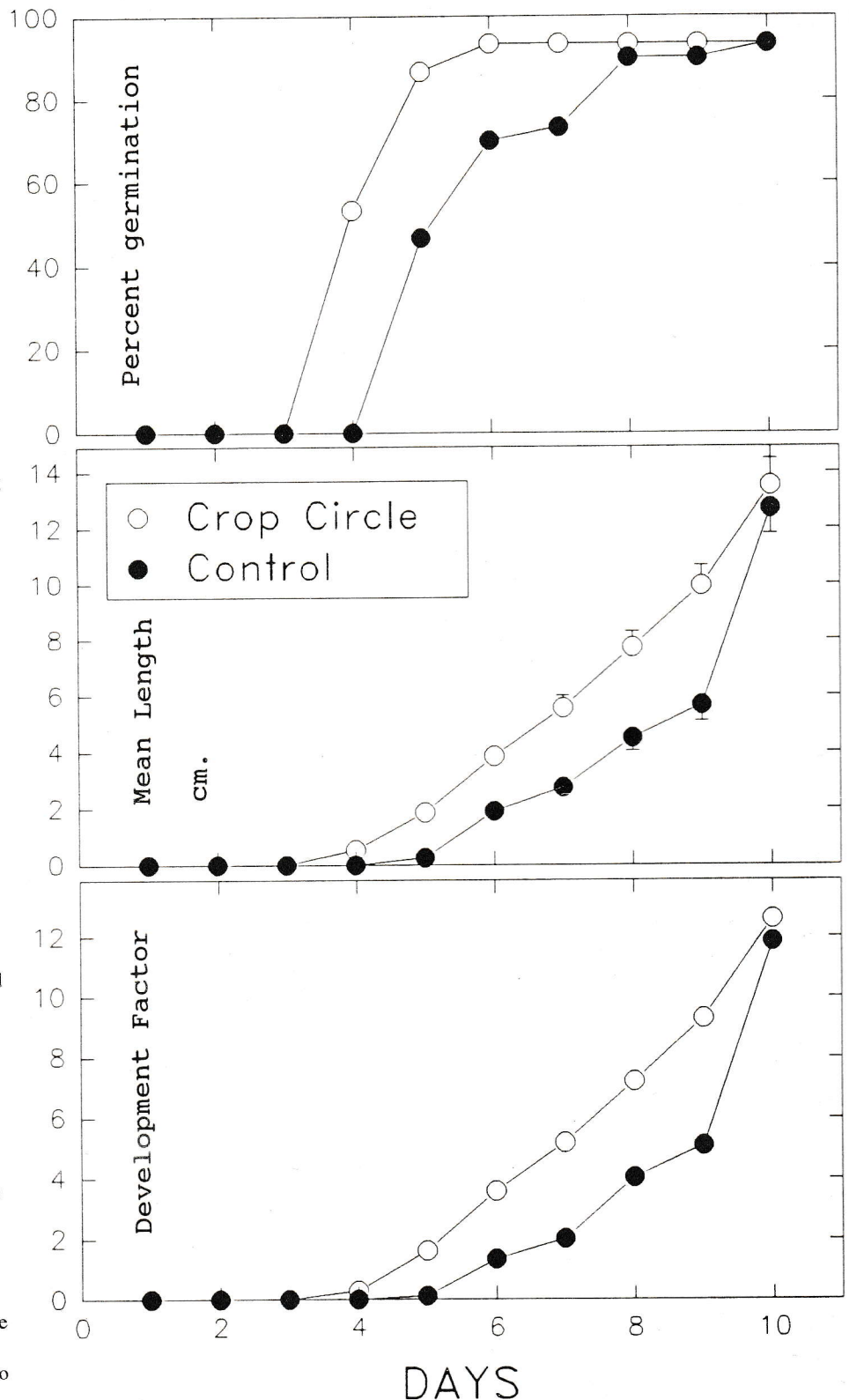

MILESTONE SASKATCHEWAN

Formation created August 1992 in wheat. Germination and growth test conducted in February 1993. The germination medium was sterile soil. Soil Temperature: 16 degrees C. n = 30 seeds per group. Note: seeds from the formation were darker and about 25% smaller than the control seeds.

A transcript, with diagrams, of the 1990 and 1991 Canadian Crop Circle Report is available for \$5 U.S. or £3 sterling (postage included) from Pacific Research, Box 74537, 2803 West 4th Avenue, Vancouver, B.C., Canada V6K 1R0.

THE WORKS OF THE DEVIL

George Wingfield finds that some people take the alleged Satanic connection with the crop circles very seriously indeed.

THE IMPORTANCE OF crop circles is surely not so much their provenance as their effect on people. It is not so much their actual origin, whether man-made or the product of mysterious forces, as what people believe is their origin. And the purpose of the Circlemakers (whoever they may be) is variously perceived as serving different ends of the spectrum of good and evil, all the way from the divine purpose of God (himself/herself) to the works of the Devil and his/her legions of demons.

Having once naively suggested that the crop circles might be something mystical, even divine, I was unprepared for the quite contrary perception of these things which is held in some quarters, especially in America. This came like a bolt from the blue at a time when I least expected it. I was talking about the circles on a phone-in radio show in Phoenix, Arizona, in 1991. The tone of the show was friendly and light-

hearted when we received a call from a man who described himself as a minister. What he said was not so much a question as a statement. The circles, he asserted, were the work of the Devil and definitely not something we should trifle with. He implied that those who were attracted to the crop circles and who spent time in the formations were in danger of losing their immortal souls.

I replied that I really could not agree with him. There was no reason whatsoever to suppose that the circles were evil or malign. On several occasions there had been formations which clearly depicted the

long-shaft Christian cross in the English cropfields. Could this be the work of the devil? The minister was not to be deterred. Indeed it could. Satan can easily fashion crosses to ensnare the unwary. Leave these things alone or risk damnation was his message. Before we moved on, I tactlessly wondered how we could be sure that the cross on his church in Phoenix was the genuine article and not a hoax wrought by the Devil? But then, of course, this is similar to the perpetual dilemma faced by cerealists, when it comes to assessing

more recently UFOs, UFO abductions, and crop circles have been firmly placed in this category. The whole New Age movement is viewed with concern and distaste. Fundamentalists quote that "Satan keeps transforming himself into an angel of light" (II Corinthians 11:14) and say that his most clever deception has been in blinding many to the fact that he and his demons really exist.... "do not be deceived! The Devil and his demons are real and you need to resist them continually."

The custodians of the faith who zeal-

ously guard against Satanic incursion keep a very low profile since this is a highly sensitive subject. But an event in 1990/1991 clearly demonstrated the Roman Catholic hierarchy's attitude to these matters. A nun (who must remain nameless) became most intrigued with the crop circles at that time. An extremely pious woman, who spent much of her time in prayer and who undertook a series

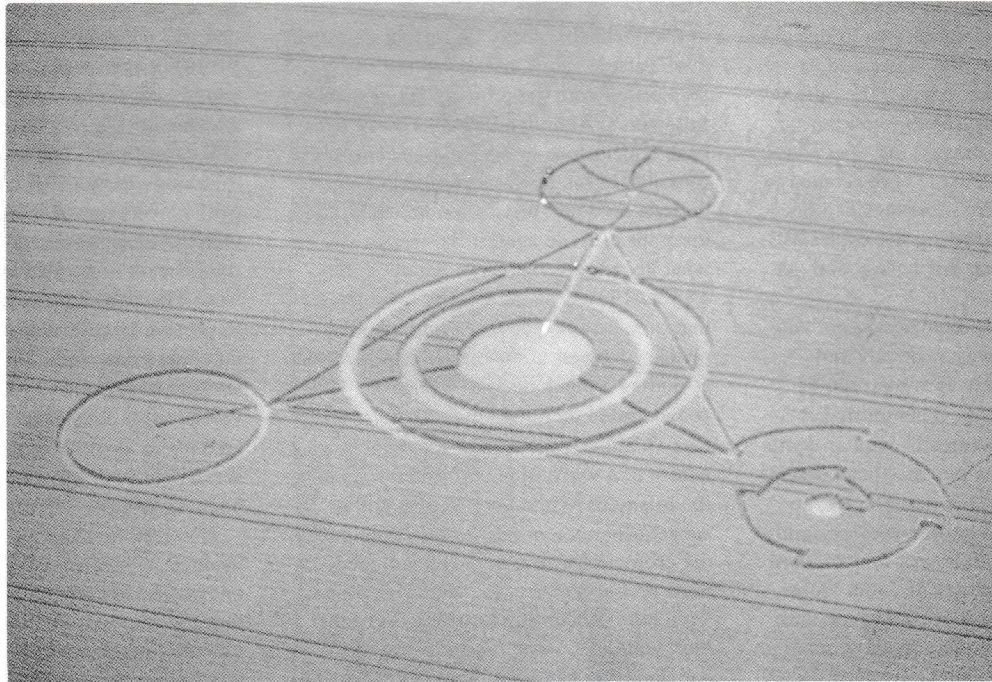

The great pictogram which appeared at Barbury Castle on July 17th 1993 which many hold to be an alchemical symbol possibly associated with the practice of ritual magick in the cornfields

the crop circles !

There should be no surprise at this stance by Christian fundamentalists. Many of them have long held that "the whole world is lying in the power of the wicked one" or "that the one called Devil and Satan is misleading the entire inhabited earth", which are interpretations of passages from the New Testament. Spiritism and spiritualism are seen as bringing people under the influence of demons and these practices should be resisted at all costs. Likewise crystal-ball gazing, use of Ouija boards, ESP, palmistry and astrology are condemned, and

of of pilgrimages to Medjugorje in Bosnia-Herzegovina, she had no doubt that the circles were signs given by the Blessed Virgin Mary. The rationale for this was that among the prophecies vouchsafed by the BVM to the young visionaries of Medjugorje (who have had regular visions of the BVM there from 1981 until the present day) was one that said she would make her mark all over the world in the coming ten years. (One could speculate here that the true circle phenomenon ceased in 1991 ...)

This saintly woman had also experienced many Catholic miracles associated

with what cynics term Mariolatry. Both in England and in Medjugorje rosaries had turned to gold, the sun had been observed to dim, to spin and to "dance" in the sky, and sometimes an "odour of sanctity", like roses, was perceived in her presence. Her devotion was such that she insisted on going ahead with a trip to Bosnia at a time when that whole country was in a state of turmoil and the Foreign Office had tried to deny her access. This belief regarding the circles and the BVM was not the casual whim of an uninformed person but something deeply and intuitively felt.

Her mistake was to write to the Pope requesting that Mass be said in a crop circle. This must have set an alarm bell or two ringing in the Vatican! Not long afterwards she agreed to meet me because of my research into the circles, but only on the hallowed ground of the Catholic shrine at Houghton St Giles near Walsingham. By then she had changed her tune considerably. She was no longer keen to discuss the circles which she now described as being the Work of the Devil. The only true path to salvation was through the church and through prayer; all else was mischief and distraction. There seemed to be no doubt that sharp messages had been sent from Rome instructing her ecclesiastical superiors to quash this heresy and get this nun back into line.

Most people in this country do not take these things in any way seriously and conceive Satan merely as some relic of mediaeval superstition. This journal is often graced with pictures of jocular devils in the crops and even our masthead depicts the god Pan as a satyr dancing in a crop circle. But there are people who evidently view these things with horror and concern and for whom the spectre of Satan looms large and real. Thus it occurs to me that, if the Spanish Inquisition currently held sway in this country, the Council of CCCS (and the staff of *The Cerealogist*) would all be chained and paraded dressed as insects, before being burned alive at the stake!

It comes therefore as no surprise to find this attitude towards the circles, and those most involved with them, lurking at every turn in an otherwise quite amusing, if inaccurate, book by Jim Schnabel (*Round in Circles*, reviewed in the last issue of this journal). He suggests that the circles are made by people engaged in "cosmological terrorism". He alludes to anonymous letters written in blood, animal sacrifices in circles, speaking backwards in Latin, "spreading the word of the Antichrist" and of the Satanic ritual murder of a vicar. What connection all this has to do with the circles, apart from in Jim's fevered imagination, goodness only knows! The whole thing, it is suggested at one point, is

a plot to "undermine orthodox religion". If ever one sought a conspiracy theorist, you have no further to look than Mr Schnabel!

He goes on to describe CCCS as "clearly a religious organisation, with a decidedly pagan flavour". There is the "pagan motif" of *The Cerealogist*, erstwhile organ of the CCCS, --the aforementioned priapic figure of Pan, with horns and cloven hooves, dancing in a crop circle. It is implied that the scholarly John Michell is a blasphemer by virtue of his 1977 essay in defence of a poem by James Kirkup. Schnabel and his cronies go on to consider that CCCS might be a "front organisation" for a secret Satanist cult known as *The Friends of Hekate*. In one part of the narrative Michael Green is discovered one night on the Wansdyke, one of four "black-cloaked hooded figures", with the clear implication that he has been engaged in some evil Satanic ritual.

Can Schnabel really be serious about all this "Satanic" stuff and its having any connection with the crop circles or their followers? Although he backs away from such conclusions in his Epilogue chapter (possibly at the instigation of libel lawyers) there is no doubt that, when he embarked upon his crusade against the circles and what he perceived as their Satanic influence in 1991, he was entirely serious. At that time he and Robert Irving, whose primary interest in the circles was directed at finding a black magic connection, concentrated their attention on the role of Rita Goold and their quest assumed the nature of a witch-hunt. This centred on the infamous White Crow letter, and subsequent anonymous letters relating to the crop circles, which they concluded, most probably correctly, had originated from her. According to Irving, Schnabel took with him, when he first went to confront Rita Goold, a bible and a crucifix. In a public statement which Rita issued in December 1991, she said: "Has Mr Schnabel completely lost himself in his fantasy world of satanic cults and occult rituals in the crop circles and forgotten to find his way back into reality?" She continued "...numerous friends and colleagues of mine have been the recipients of telephone calls by Mr Schnabel in an attempt to slur my reputation, accusing me of 'hoaxing' and (being) engaged in 'black magic' activities with not a shred of evidence to substantiate any."

To what can we attribute this American zealot's bizarre search for evil and Satanic influence in a phenomenon which many have seen as beautiful and benign, if not spiritual? Jim Schnabel acknowledges his Catholic background and the fact that the school which he attended was run chiefly

by members of *Opus Dei*, an extreme Catholic organisation, though he is far more reticent about any present links with it. He was particularly coy about his former address: 88 Marlborough Road, Grandpont, Oxford, and always gave his address as c/o Lincoln College, Oxford, even long after he severed his connection with that college. Perhaps it was because the student house had a known association with *Opus Dei*, whose Oxford headquarters are at Grandpont House barely two minutes walk away. There has been no secrecy about his more recent Oxford address. Currently Mr Schnabel denies that he is a Catholic.

A curious pointer to the existence of a possible link between what was going on and some hieratic involvement came at the beginning of 1992 when I had no inkling of such interest. I was sent anonymously a copy of the novel *The Fraternity of the Stone* by David Morell. Inside was written "Not all is fiction. Verb. sap. -- Frater...(various initials)". The story concerns a desperate and deadly quest which had led to a bloodthirsty slaughter in a monastery. The brief preface is as follows:- "In some respects, the intelligence profession resembles monastic life with the disciplines and personal sacrifices reminiscent of mediaeval orders." (quoted from The U.S. Senate's Church Committee Report on Intelligence Activities, 1976). Of course one could always construe this as further disinformation, like the controversial tapes, but, if certain people are so anxious to cloak their purpose in a smoke-screen of disinformation, one really must begin to wonder what they have to hide.

Having peered dimly into this web of intrigue, one can perhaps more easily understand actions by examining motivation. If one ever thought the Jesuits were extreme, one has clearly never encountered *Opus Dei*. Founded by Monsignor Josemaria Escriva de Balaguer, who died in 1975 and who was recently canonised, this organisation is dedicated to preserving a strongly conservative Catholic faith and is the favourite of the present Pope. From the late 1970's *Opus Dei* funnelled large sums of money into eastern Europe -- Poland in particular -- via the Church. In this work they collaborated closely with the CIA who saw the Church in this context as the chief bulwark against communism. The present Pope was the main contact point and was very close to the CIA, receiving weekly briefings from their Rome station chief. It is rumoured that the Banco Ambrosiano scandal, in which huge sums (up to £800 million) were supposedly lost by the Vatican, was really a money laundering operation to render funds anonymous and shift them

east. If this is true, one can only marvel at the success of the exercise and be grateful for the Pope's role, and that of *Opus Dei*, in whatever part they played in helping to undermine the tyrannical communist regimes of eastern Europe.

Upon his election the Pope's first act was to pray at the tomb of Josemaria Escriva. Now that, years later, the Communist demon has been exorcised there are other Satanic influences to be combatted. The Pope is very concerned with the apparent rise of "Satan" in the world and his chief demonologist is one Corrado Balducci. They believe that some great war with Satanic forces is looming. All of this is possibly connected with the prophecies of Fatima with which the Pope is said to be deeply concerned.

Much of *Opus Dei's* "work" is clandestine and its methods ruthless. To achieve its purpose its workers must sometimes deny not only belonging to *Opus Dei* but even that they are Catholics at all. Their anticipated approach to supposedly Satanic manifestations might be as follows. First they would ignore them in the hope that they went away. Then, if that didn't work, they would try to ridicule them publicly. In doing so they would form alliances with others similarly inclined even though from a completely different standpoint.

Just such a campaign of ridicule and vilification has been relentlessly carried out with regard to the crop circles and the crop circle community, as I have described in previous articles. Although it is evident that most of those involved have no "political" connection, one is certainly entitled to enquire whether inspiration for this campaign did not originate from the perception of the circles as Satanic by a particular religious organisation.

Miracles and manifestations of the paranormal involving religious belief invariably hover dangerously near the divide between the divine and the demonic. For centuries the Vatican has treated such events with extreme caution, especially when Marian miracles are concerned, since the subjects of visions and the entities perceived are not always readily identifiable. Usually the Vatican takes many decades before it acknowledges any such happenings as miracles, by which time the manifestations have most likely ceased. This caution is certainly the case with the current Marian miracles of Medjugorje, and even the 600-year-old on-going miracle of the liquefaction of St Januarius' blood in Naples is not officially recognised as a miracle by the Vatican.

Usually the whole character of such phenomena is so closely linked to the consciousness of the percipients that they, subconsciously at any rate, determine



The ORIGINAL of this drawing and other of Merrily Harpur's cartoons for The Cereologist will be on sale at the Conference. Show a cloven hoof and get 25% off!

whether the events are seen as divine or diabolic. Within the confines of a church or shrine some control by the authorities is possible and they can hush up events should they ever start to appear Satanic in nature. But other events, such as the crop circles, are entirely beyond any control

and, whatever their true nature, they will inevitably be seen by Christian fundamentalists as the works of the Devil. One man's miracle, it seems, is another's diabolical manifestation and, as such, it will no doubt be disparaged and ridiculed until such time as the manifestations cease.

CIRCLES REVIEW OF 1993

James Chapman takes a look at a rather motley bunch of formations which appeared in the fields during 1993.

THE 1993 CROP circle season has been, yet again, a fascinating and confusing few months. The circles started slowly and it was feared that 1993 could be something of a flop -- but then they began in earnest.

The season opened with a large doughnut shape in oil-seed rape at Aston Rowant, Oxon. This was quickly followed on May 2nd by a 115 ft circle with scattered grapeshot near Saltford, Bath. This one caused a flurry of interest as it was in very immature wheat and it is unusual to find circles in such green crop. It was soon dismissed as a hoax once fully inspected.

An outbreak of circles followed near East & West Ilsley in Oxon. Four of varying size were found in rapeseed and generally views on them were favourable.

It was not long before the circles returned to their usual haunting ground near Avebury and Silbury Hill. A small dumb-bell appeared near Stone Avenue together with two grapeshot. This seemed good and lay on the line of the 'Michael Current'.

A ringed circle near Silbury Hill was found with circle and ring laid radially. However Busty Taylor reported that from the air the ring was not fully concentric with the inner circle. [It later transpired that this one had been faked by "Bill Bailey".] A large shape nearer Avebury including a circle, cross and 18 wavy lines, was particularly unattractive and evidently manmade.

More pictograms followed near Avebury; two dumb-bells at the Avenue and at Lockeridge were of very similar design.

The focus then moved to Sussex where a remarkable series of shapes, including two classic Celtic crosses, were found near Sompting. Other pictograms here and one Celtic cross then began to suffer mutilations: major additions completely changed the appearance of the pattern. A large circle was laid over the Celtic cross, transforming it into a tambourine shape, a circle with four bumps. Other initially simple circles were turned into long multi-circle pictograms. The Sussex CCCS was even rumoured to be attempting to buy part of the field containing a ringed dumb-bell from the farmer!

Soon afterwards formations began to appear alongside the motorways, where a remarkably rich and varied series of shapes were spotted, especially by the M25 and M4. They included various arrowheads, squiggles and concentric triangle outlines.

A huge 400 ft pictogram at Boxford, Oxon., by the M4 caused some excitement, looking like a 1991 style series of circles and rings. However the farmer reported seeing tracks into the grapeshot when it was fresh and Anthony Cheke found a curious honeycomb effect on part of the laid crop reminiscent of the tread on a pair of hiking boots. Another similar pictogram was seen a few days later

opposite the first. The near-identical shapes of the patterns must mean they should be attributed to the same source.

It was said that Irving and Schnabel had expressed the intention of switching their hoaxing activity to beside the motorways in 1993 so that more people would see their creations. If so, either a new band of Wiltshire hoaxers was at work, or were they returning to the Avebury area on the odd occasion to keep interest going?

Dorset was host to a larger number of circles than usual, mostly simple and attractive patterns, with Maiden Castle, Long Bredy and Gussage All Saints the major examples. There were also many reports of aerial luminosities in the Maiden Castle area.

I was lucky enough to be the first person to inspect a complex shape in the crops at Goodworth Clatford near Andover. The main circle was radially laid and layered and there was a curious S-flow in part of the ring.

While this was most impressive, other parts of the formation were very untidy and I wondered if they could have been added later by hoaxers, although, as I was apparently there before anyone else, it seemed most unlikely.

A huge 300 ft cruciform pictogram was discovered at Charley Knoll near Loughborough which was most impressive from the air and also at ground level. East Midlands CCCS were very happy with the formation and Michael Newark, the dowser, was particularly pleased with it, but there were, almost inevitably, rumours that it was manmade -- possibly by a certain member of BUFORA.

On July 8th a new "Charm Bracelet" was found near Swindon causing much excitement initially. It was a near carbon copy of the 1992 shape, the only major difference being that the central quartered circle was replaced by a novel 'eye' shape. Most people felt quite sure that it was a fake and its position alongside the M4 motorway aroused much suspicion.

A new collection of pictograms around Avebury and Lockeridge caused excitement, particularly a set of three tailed circles and the so-called "Snail & Trail" -- a comma-shaped circle with zigzag and grapeshot below. Both of these formations were laid very neatly and precisely.

A formation at Etchilhampton Hill was generally well received. This had a large central circle surrounded by six equal sized satellites, each connected to the centre by spokes. This type of formation was to be repeated later near Devizes, where a quintuplet, again with spokes, was discovered and harvested within hours.

A large pictogram at East Kennett became the focus for several classic

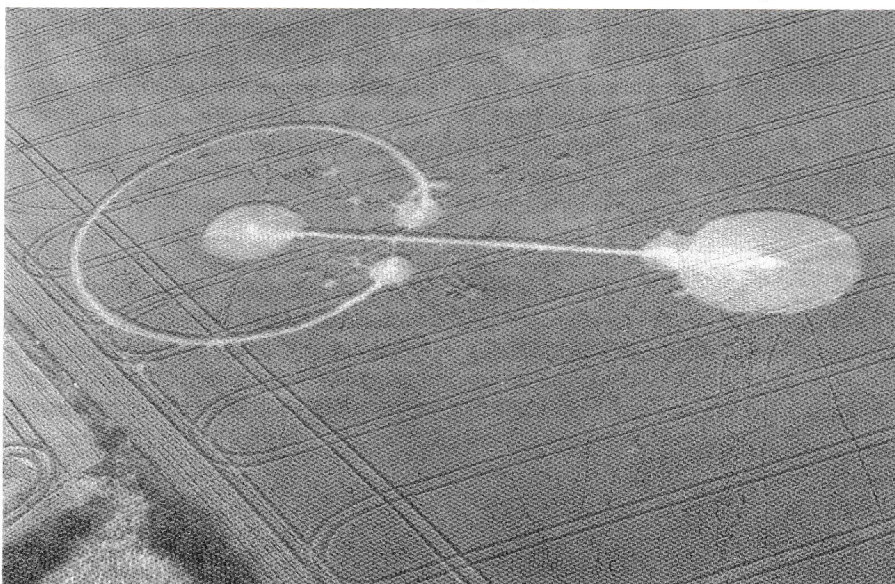

Fine pictogram at Wheatcroft Farm, Nuneaton, Warwickshire.

TONY CALDICOTT

mysterious effects. A standing central tuft of crop was upright at 9 am when first inspected, but was found twisted and flattened just two hours later. One witness saw white lights "galloping through the corn" while inspecting the formation.

One of the best formations was at the Hogs Back near Farnham. Five formations were discovered there in all, including one like a simplified Barbury Castle type, and also a circle with a standing crescent of corn inside. Colin Andrews and others were convinced these were the genuine article. Another large triple dumb-bell (see photo) at Windmill Hill, Avebury, was proclaimed genuine by many.

Four formations were spotted at Cheese-foot Head, *supposedly* abandoned by hoaxers Doug & Dave. These included a large dumb-bell, a four-circle pictogram and two singletons.

As the season drew to a close a huge formation was found beneath the White Horse at Cherhill. A mammoth six-circle pictogram, it was well laid and well received [though roller marks were apparently visible in this --Ed.].

As the harvest continued, reports were still rolling in, including new formations at Avebury Avenue, Silbury Hill and Lockeridge, not to mention several formations in Yorkshire and other parts of the country.

In the Next Issue

In the next issue of *The Cerealogist* there will be a full review of the *Report on the Results of Project Argus, An Instrumented Study of the Physical Materials of Crop Circles* (written by members of the Project Argus Team, edited by Michael Chorost).

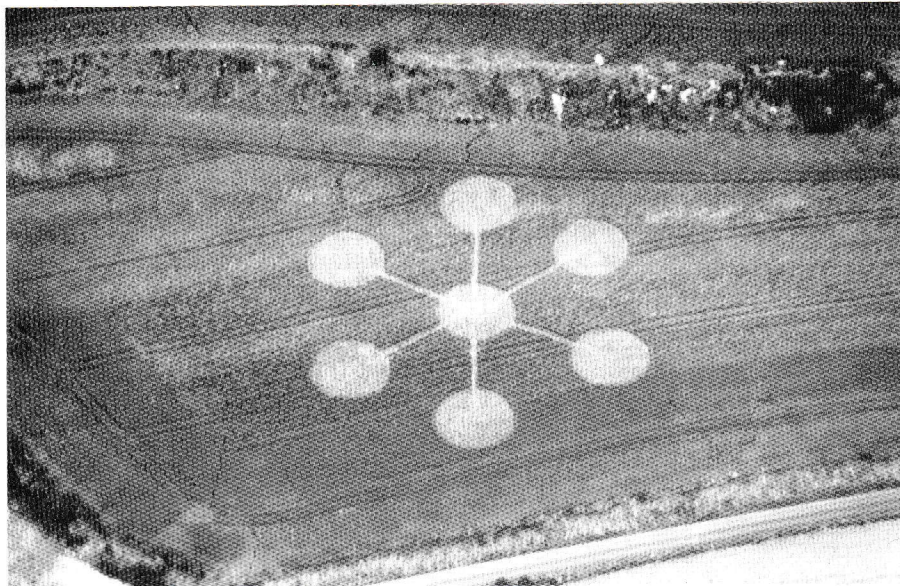

The "Quartz Crystal" formation at Etchilhampton Hill near Devizes found in late July.

BUSTY TAYLOR

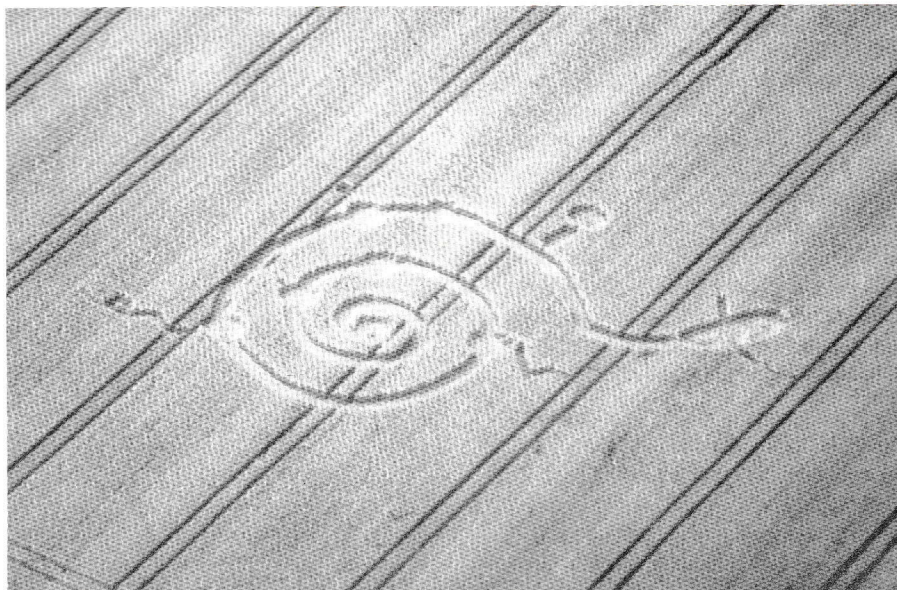

A poorly executed spiral terminating in a "fish" at Upton Scudamore, Wilts.

GEORGE WINGFIELD

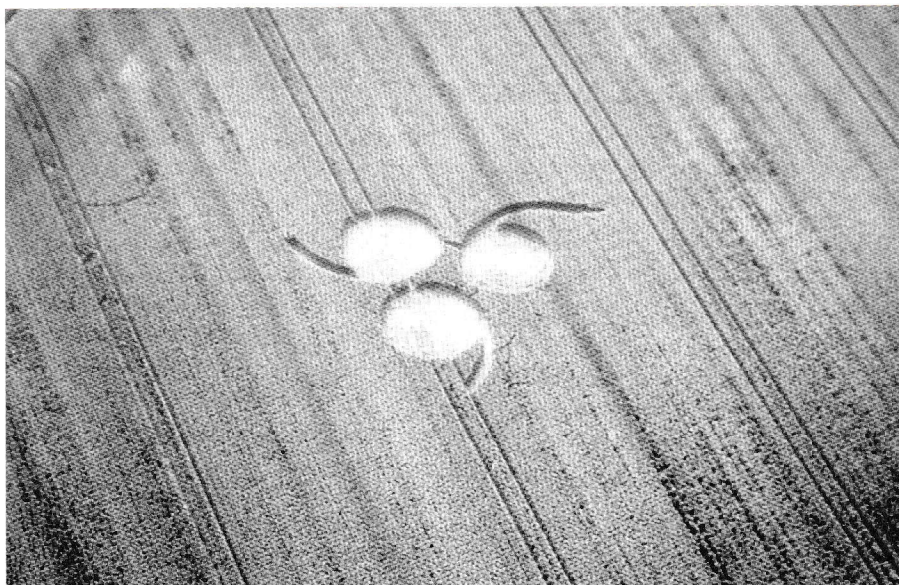

The "three sixes" near West Overton thought to be faked by those who ringed the T-junction

BUSTY TAYLOR

Peter Sorensen contributes his notes on some of the 1993 crop circles and diagrams of the numbered ones which he describes.

1) THE AMAZING RING encircling the T-junction on the road between Alton Barnes and East Kennett at the turn-off for West Overton. Like everyone else, when I first heard about this I thought it was a joke. But on close inspection it had many features of the genuine article, including dozens of bent stems --some curving gently with no kink, others bent down at the node a perfect 90 deg. There are many rumours about this one being hoaxed, but nothing short of a movie showing it being constructed would make me bat an eyelash--and they would have to explain those stems !

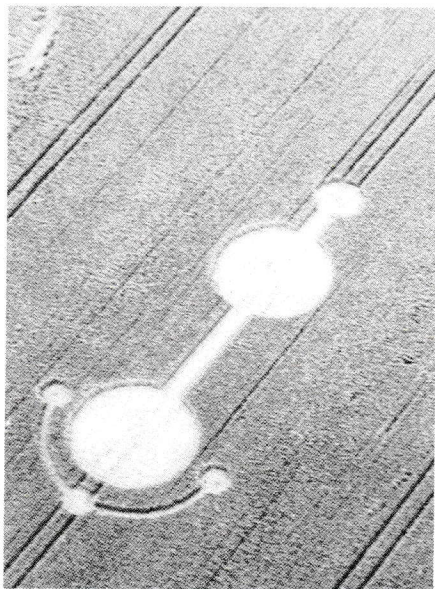

Impressive triple dumbbell at Windmill Hill

[According to information which I have, the farmer's son actually caught the men who made this one in the act. He shouted at them as they loaded their rollers back into a van at 6 o'clock in the morning--Ed]

It was the first of several to appear in the vicinity of the junction, making this the new Alton Barnes (since the Carson's farm was barely touched by the phenomenon this year). It came in mid-July and was about 90 ft in diameter. This and most of the others were carefully surveyed by Chad Deetken and/or Colette Dowell.

2) The "Overton Oval" that appeared on Lurkeley Hill, near the T-junction, a week or two later. It grew the top circle a few days after first forming. An interesting feature was how a small patch of oil-seed rape plants (an aberration in the wheat-field), connecting this circle to the smallest circle, was incorporated in the design.

3) The "wheelchair" was one of the last crop circles of the season, and is especially remarkable because it first formed across from Silbury Hill --where it was immediately cut down by the farmer --and then re-appeared near the W. Overton T-junction! A few days before the first one, one of the best-liked croppies had joked that the 'Disabled' symbol might appear to signify the human condition. Ilyes and I were the first in the Silbury one, at dawn on the day it appeared, which was the day she had to fly back to the States. So she calls it her *bon voyage* circle !

4) The "3 commas" formation also near the T-junction. Some people had negative physical effects in this one, and called it the "6 6 6" instead. About 60 ft across, it appeared on the same night as the ring.

5) Last crop circle of the year (at least in my neck of the woods) this 40 ft design

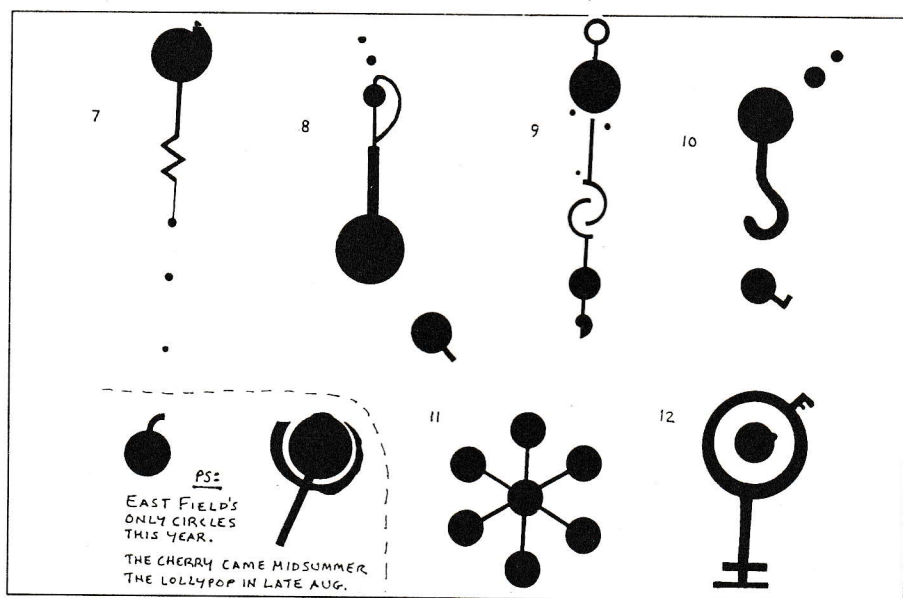
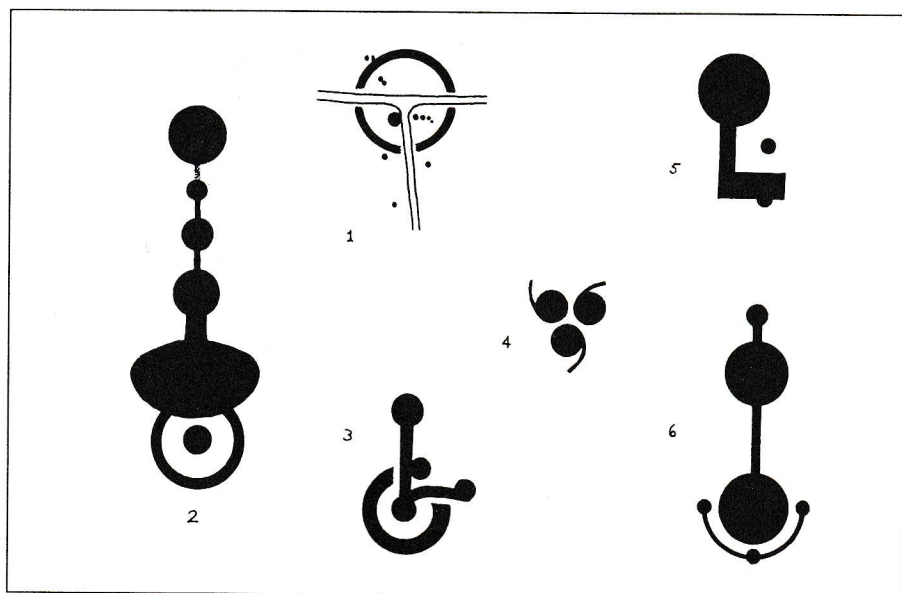

appeared on about Sept 1st on W. Overton hill in a last field of standing wheat.

6) This pretty dumb-bell on Windmill Hill near Avebury appeared in early August (see photo also).

7) The 200 ft. "zig-zag" on Waden Hill, at the end of Stone Avenue. Late June.

8) Before the zig-zag, this looped pictogram appeared. About 150 ft long.

9) The Cherhill pictogram was a favourite for some. When new it included fine details such as "curtains" of stalks separating circles from lines; these were made from a single row of stems going for 15 ft.

10) Early June, near Devizes, about 40 ft.

11) This beauty, 175 ft across, appeared on Etchilhampton Hill, also near Devizes in late July. I call it the "Quartz Crystal" because it diagrams the fundamental unit of molecular structure in that crystal.

12) The first pictogram worthy of that name in 1993, on June 4th, was not even in England. It was found at Kennewick in Washington State. Ilyes was on the scene in a few days, surveying it and taking samples to send to Dr Levensgood who pronounced them consistent with the genuine circles effect phenomenon.

14) A spectacular formation, this giant must have been 300 ft across. It appeared near the Punchbowl at Cheesefoot Head in early August and covered a record amount of territory ! I'll be very interested to see analysis of its geometry.

15) This pictogram appeared just a field away from (14) at about the same time. The main part of it was about 225 ft long, with the two little bits (15a & 15b) farther away than shown here, maybe twice as far.

16) This and the rest through to (20) all appeared in the first week of August, along

a ridge called the Hog's Back, which runs between Guildford and Farnham. They were all about a quarter of a mile apart, so finding them from the air, one at a time, one after the other was quite an exciting experience. Each of the circles was about 180 ft in diameter. The first of the series was a classic circle with a ring.

17) This crescent moon was the reason we made the flight farther south than usual. Colin Andrews had been notified that the crescent was there, and he was anxious to see it from the air before it was harvested. The combine was actually in the field when we flew over! This exact design had been foreseen by the Hopi elders.

18) A basic symbol in sacred geometry!

19) The interesting thing about this one was the little (50 ft?) "signature" nearby.

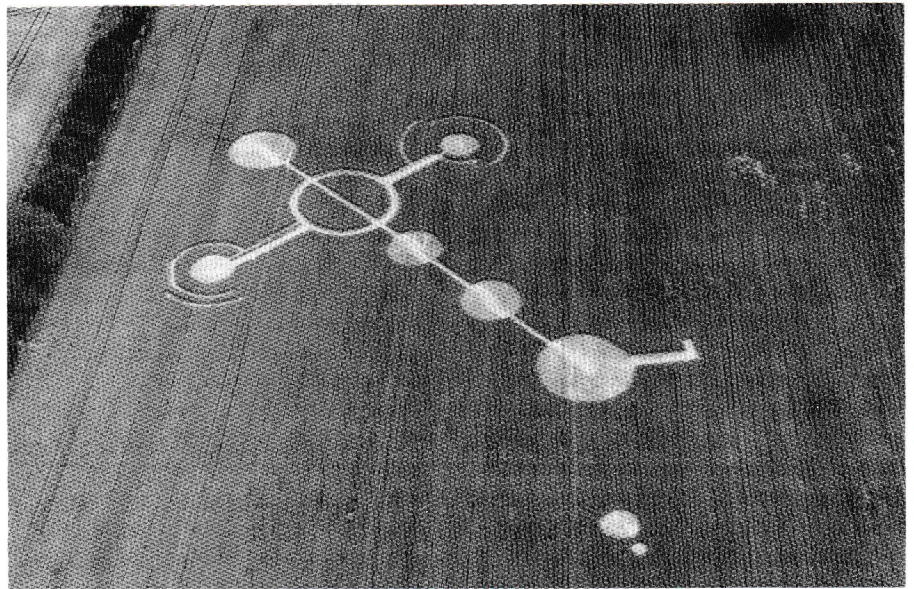

TONY CALDICOTT

Despite suspicion, this huge crucifix at Charley Knoll, Loughborough, looked magnificent.

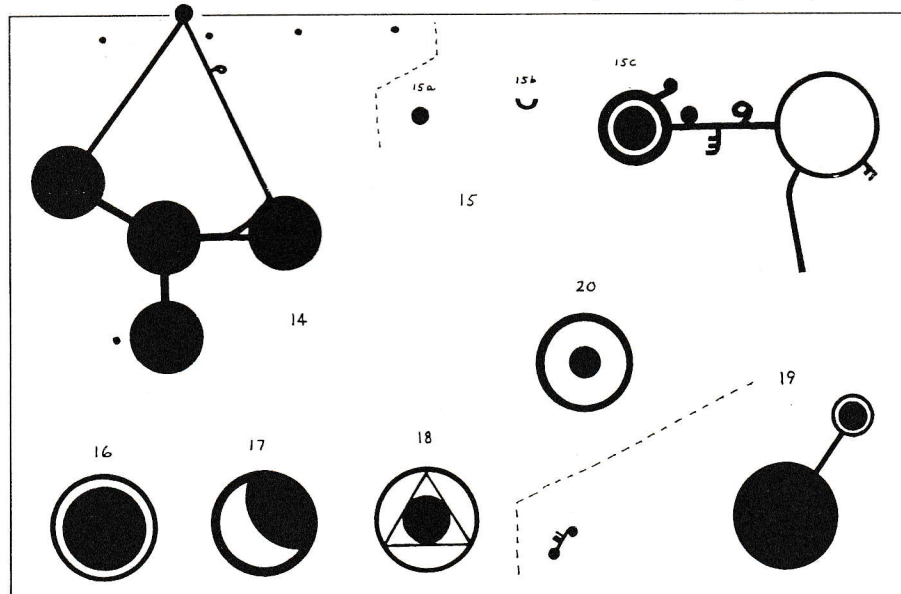

20) This circle and ring have the same proportions as a formation which appeared early this year near Silbury Hill, but was half the size of this. (See J. Chapman's report, p 10) This is the only one of the Hog's Back circles not in line with the rest.

Two harvested formations

Busty Taylor spotted these two circles about 400 yds east of the Cherhill pictogram on Aug 31st. as we were driving by. We couldn't stop then but returned two days later to find some of the most peculiar things of the year. Although the field had already been combined and bailed, the lay of the circles was for the most part still quite evident. The combine cuts about 8 in. above ground, so wheat pressed flat generally escapes the blades (which are like titanic barbers' clippers.)

The lay was far from straightforward, as a glance at the diagrams will show. The crop frequently reversed direction and made odd turns. Each circle had smaller circles within it. The second circle had oddly shaped patches of crop which it seemed had never been flattened.

But by far the most interesting thing was a strange dark gray dust that was deposited in the centers of some of the swirls (marked "D"). My first thought was that it was a prank, but to my amazement I found that the chalks had become discolored, a dark orange-brown, on their upper surfaces. Every one was still white underneath and there were no such colored stones elsewhere in the circles or the field. Could the dust have reacted chemically with the rock -perhaps in the presence of microwave energy? In a few cases I found small patches of the color on stems too. The dust was all over the stems and ears, making the swirls noticeably darker.

CIRCLES TO THE EAST OF CHERHILL Discovered 31st August in harvested wheat

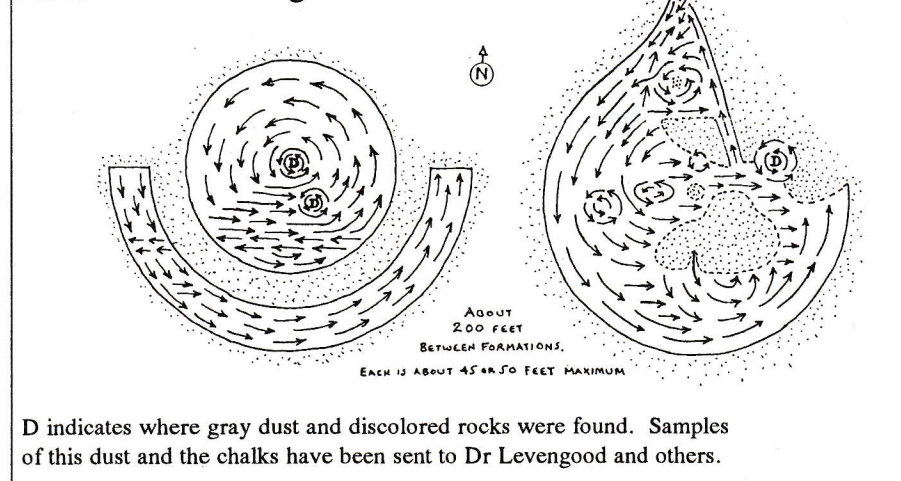

D indicates where gray dust and discolored rocks were found. Samples of this dust and the chalks have been sent to Dr Levengood and others.

A VIEW FROM ACROSS THE POND

Paula Louis from New York offers us some reflections on the English Crop Circle scene as observed from an American perspective.

AS BOTH THE circle season and the silly season in England draw to a close, and we approach the second of the three Uranus/Neptune erratic, confusing conjunctions, it feels the appropriate time to comment on that to which I have "born witness".

Despite the plagiarism, paranoia, lack of patience, perplexedness, persecution, one or two parasites and pancaked porcupines, there has also been camaraderie, genuine communication, compassion, catharsis, concern and cosmic connectedness observed amongst the "tribe" of us drawn to the fields and conferences this year. In as much as many have complained to me that they believe the original phenomenon is being diffused by the concurrent phenomenon of the human made formations, I have had to beg to differ with this complaint.

My perspective on this includes my dealings in America, since I publicized various English circles researchers who had come here. I was well aware that Doug and Dave had hit the big time in the States as being the most widely circulated explanation for the formations (without much to show for it, other than a private meditation done on their behalf in America by two channellers who were asked by their guides to help repair the damage done by all the animosity which they had attracted to themselves). When the time came for me to approach the press, (*Time*, *Newsweek*, *NY Times*, *OMNI* magazine, *New Age Journal* and the TV magazine *20/20*), I was surprised by their response, but learned much about the mainstream American press's attitude towards the circles. In so far as they had each done stories in the past, no one I contacted was interested in following up their original stories, unless I could provide them with a "sensationalized" (their word) angle, which I would not do. In addition, several of the reporters I spoke to admitted they were personally drawn to the phenomenon, but had to stay professionally subservient to their editors or producers. As a result of these interchanges, I let go of my hope that the crop circles would receive fair and widespread coverage by the mainstream American press. This all took place in 1992.

A personal view

In 1993, a tentative attempt has been made by an American TV show to contact some

American researchers to do a follow up on their initial story. It would be wonderful if this is indeed carried through, but my lesson from last year taught me what my intuition had sensed: that the crop formations and their various meanings are not meant to ignite a blaze in humanity at large, as it has done in the hearts, minds and souls of some of us. I had a dream about the formations in 1974 (which I documented then) and so was conditioned and primed for them when I saw photos of the formations in 1989. In other words, I had as much invested in wanting to see the phenomenon "catch on" as anyone, yet I have let go of this desire. I have also found that my opinion of the impact of the human made formations is vastly different from that of some of my friends and fellow researchers. From my perspective, all the human circle makers from Doug and Dave to Bill Bailey (who created one of my favourites) to Schnabel and Irving are just as viable a part of this phenomenon as are the "authentic" formations.

The Concise English Dictionary gives the following description of phenomenon: "that which appears or is perceived by observation or experiment, especially a thing or occurrence the law or agency causing which is in question; a remarkable or unusual appearance". Does this not describe both the human and authentic formations? On a more practical note, I can well understand why in a country as expensive to live in as England, my crop circle cousins complain about the costs of investigating human made formations. Wouldn't it be nice if Schnabel and Irving would make financial contributions to various researchers to cover their costs since they have not (unlike some other humans) always reported which formations they have done. I also understand (although not fully until I can stand in another person's shoes), what it might feel like to be deliberately tricked into a situation where I would be publicly humiliated, for the incident to be broadcast internationally, and to then have to go forward and honour the commitments to lecture I had made previously with openness and dignity. I applaud all whose lives I am describing here. So, it is these observations that have brought me to the point of understanding the behavior and statements made by various researchers having to do with the human made

formations, although I do not share them. I hold the belief that every single person involved in any way with this phenomenon, from bookselling to scientific research, to channelling, to laying down the plants, is carrying out an intrinsic part germane to the phenomenon itself.

The worst and the best in us

Now there have been some pretty nasty goings on, researchers attacking each other's work at conferences, an American woman publishing her English house-guest's personal faxes, attempts at copy-righting formations (!), dedicated researchers accused of creating the very formations they were surveying, as well as plenty of conjecture that various individuals were providing the British or American intelligence services with information. Yet I still stand firm that all of this holds meaning on many levels, just as all thoughts, words and actions not related to the crop formations hold meaning in both the physical and multi-dimensional worlds wherein we dwell. I put forth the proposition that whatever striking photographs and enamoured words we share about the formations, we are also carrying the vibrational residue of all the unpleasantness as well. I urge us all to remember we are under public, professional and religious scrutiny, not to thwart our words or behavior, but rather to take the time and effort to search for how this can bring out our best, and to remember the difference between destructive and constructive criticism.

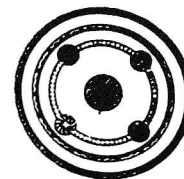

JUPITER POWERWEAR CROP CIRCLE T-SHIRTS & SWEATSHIRTS

The beautiful crop 'circle' designs silk screened on 100% cotton T-shirts, long and short sleeve, and fleecy-lined sweatshirts.

For coloured leaflet write to :-
Judy Young, Lazy Moon Farm,
Upper Brailes, Banbury, Oxon. OX15 5BA.

THE BLUFFER'S BLUFF IS CALLED

Lucy Pringle goes to Suffolk to observe and report on Jim Schnabel's attempt to reproduce the 'Celtic Necklace' (or 'Charm Bracelet') crop formation of 1992.

The challenge

SATURDAY THE THIRD of July dawned clear, bright and sunny in Pentlow, Suffolk. The birds sang lustily as though awakening to a special day and indeed they were right that this was the occasion when Jim Schnabel was going to give an exhibition, demonstrating beyond all doubt that, as claimed in his book *Round in Circles*, he was the perpetrator of the "Celtic Necklace" (or as some would call it the "Charm Bracelet") found to the west of Silbury Hill on the morning of 17 August 1992.

I had arrived the previous evening and mentally was all prepared to pack my bags and walk away from this phenomenon if Schnabel could prove to me conclusively that he had indeed made the Celtic Necklace. I have on many occasions 'gone away' for a few days, leaving the phenomenon behind me, only to be drawn back by all manner of inconsistencies for which, strive as I might, I could find no logical or rational answer. This was going to be a major test and one which would determine my future role, for together with Ralph Noyes, John Haddington, Grant Wakefield and many others, I believed he was going to attempt to reconstruct this wondrous formation.

I was prepared to give Schnabel a fair hearing and a chance to demonstrate what he could do. This report is therefore written with the aim of being as dispassionate as possible.

On 27th May 1993 Schnabel had attended a meeting of the Suffolk CCCS and after answering questions had accepted Montague Keen's invitation to perform this feat (or so I had understood) in one of Monty's fields at School Barn Farm, Pentlow, Suffolk. Montague also kindly asked people to send him requests for particular features from the Celtic Necklace or other formations that they wanted replicated.

I requested a two inch wide semi-circular band going ten foot four inches into the crop, each edge starting from a shaft (which was a feature that I had seen). If Diana Clift and I had not seen the band cross a tramline we would never have spotted it as the crop closed over it so completely that it was not visible where it met the shaft. (The effect was similar to flying over a forest of trees, the canopy of which obscures the forest floor beneath.) Grant Wakefield, who took many spectacu-

lar photographs of floor patterns of the Celtic Necklace, requested replication of the special four-layer effect which he had recorded on film.

Why not a replica ?

Imagine therefore my surprise when Monty Keen told me that Schnabel was NOT going to reproduce the Celtic Necklace, NOR was he going to reproduce my request NOR was he going to attempt Grant's layering effect. The reason he gave for the latter was that it was impossible to achieve such an effect in immature crop. Little did he know that only the previous day I had observed *exactly the same effect* in a startlingly beautiful formation in immature wheat at Goodworth Clatford in Hampshire. Not only had I observed that very effect but I had also seen the most breathtakingly complex interweaving of stems as the radially laid wheat burst from the circle, meeting the outside ring, and creating the most elaborate interlacing in the springy undamaged crop. When I later recounted this to him, he brushed it aside and quickly changed the subject for a safer one.

As Saturday morning wore on, the barbecue under Busty Taylor's supervision was prepared, and sandwiches, plateful after plateful appeared to feed the expectant observers, many of whom like Stanley and Sue Morcom, Grant Wakefield, Una Dawood, Jo Holland, Andrew Winn, Colette Dowell, Busty Taylor, Peter Sorensen (in charge of recording the event on video) and others, had travelled some considerable distance to witness this event, together with many members from the local Essex and Suffolk branches, including Dr Lester Smith's companion who had been with Dr Smith when he had had the healing experience in "Brian the Snail" at Alton Barnes last summer. Dr Smith aged 88 sadly died last November inspired to the end by his experience in Wiltshire. The appointed hour for Schnabel's arrival, 1.30 pm, came and went; two o'clock also passed. Had he funk'd the issue, had he backed away from the challenge? The general opinion was NO, that was not the making of the man. That he does not shun publicity is clear. At 2.30 he arrived, anxious to get on with the job. How brave of him to subject himself to this test in front of a crowd of onlookers whose antagonism was barely disguised beneath a

polite exterior. How could he win?

a) He had not endeared himself to many of us by his scurrilous and inaccurate attacks on our colleagues in his book.

b) If he produced a formation of such immaculate quality that we would in all honesty have to admit that he WAS the creator of the Celtic Necklace, many people including me would be forced to pack our bags and retire from the scene; those who were severely disillusioned might well vent their wrath upon him.

c) If he made a mess of it and failed to live up to his claims, he would be ridiculed in front of every one.

Grant Wakefield put several penetrating questions to him concentrating on the theme: "Why did he not replicate the Celtic Necklace exactly?" That he had even claimed the Celtic Necklace as one of his efforts in the first place was such a mind rocking statement to have made, that clearly nothing less than an attempt at a reproduction of the Necklace would be acceptable. Yet despite this, Schnabel did not see it that way and told us that not only would he produce one of the same family (Dharmic wheel) and of a far greater complexity, but one which once we had seen it would convince us of his claim. I put it to him that the validity of any scientific test depended on being able to repeat a test not just once but time and time again. Clearly as he would be working in immature crop as opposed to mature crop we would have to take that into consideration when inspecting the result *but the result would need to be close enough to satisfy critical comparison*. Schnabel replied that he hadn't appreciated the importance we placed upon this aspect!

The design under the stamp

Another inconsistency which occurred to me was the fact that he tells us in his book that when he makes formations they are of an inspirational nature and yet he also tells us that he departed entirely from this procedure in the case of the Celtic Necklace, going to such extraordinary lengths as making a diagram of the proposed formation, enclosing it not only in the envelope but taking the amazing trouble of drawing up in minute detail a replica of the diagram in the envelope and placing this diminished version *underneath the stamp on the envelope*. What enormous labour and lengths he had gone to in order

to achieve this! He puts this envelope forward as incontrovertible evidence and proof that he made the Celtic Necklace. Surely it is not beyond the realms of human endeavour that he not only steamed open the envelope, putting in the diagram *after* the formation appeared, but that he repeated the process with the stamp, either re-sticking it or replacing with another stamp with matching postmark lines?

To attempt to question Schnabel about anything which he is not happy to discuss, is quite one of the most difficult things one can attempt. He is a past master at evasion, he is better than any politician I have ever met for side-stepping an issue and going off on a lateral tack and when there are a lot of people around, this lateral tack may be very interesting to those people who may not have followed the significance of the original question in the first place. They then get hooked onto the side issue which Schnabel has skilfully engineered and start asking questions about that side issue! Therefore to return to the original question, it was necessary to display enormous resolution almost to the point of ad nauseam. I am not a Taurean for nothing! He seemed to think this whole business beyond his terms of reference.

However I know this is realistically possible as a friend of mine, not liking her passport picture, decided to replace the offending one with another more to her liking. The foreign office stamp presented no problem to her and she went through Customs quite unchallenged for the next five years!

The work begins

Whilst this questioning was continuing Schnabel unloaded his equipment which comprised a 2 ft wide green garden roller, several long white poles, two sticks with an attachment, a narrow plank, a ball of rope and a pair of scissors (provided by Monty). He proceeded to cut two equal lengths of rope from the ball and attached these lengths to either end of the plank as in the Doug and Dave technique. And so the stage was set. He then carried this equipment together with a black bag, into the field, entering via a tramline. He proceeded along the tramline until he reached the brow of the slope. At 1512 hours he inserted a pole into the ground (with some difficulty as the ground was hard) and started to make the formation using another ball of rope which he took out of his black bag and which had existing knots in it, marking the different lengths he was going to require for making radii and other measurements.

Despite being able to climb a 15ft platform which Monty had most thoughtfully rented



BUSTY TAYLOR

Jim Schnabel consults his plan after completing the "Radiation Symbol" central feature of his "Necklace" design. Note that mole drainage lines at right angles to the tramlines in this particular wheatfield happened to make for very easy access to all parts of the formation.

and which had been erected by Busty, Andrew and Peter earlier in the day, it was not possible to follow exactly what Schnabel was doing. Surprise, surprise! He was constructing the formation from a diagram and referring to it regularly. (Could this be another preposted plan?) The sun was baking down relentlessly and instead of taking five hours he had finished in just over three and a half. But what on earth were the symbols intended to depict? Peter Sorensen with his video camera had followed behind him, after letting him make the initial shape and then videoing him from different angles as he carried out his construction, making certain that he never impeded him in any way. About half way through the experiment, Busty Taylor also entered the half completed formation to take pole shots. As the formation took shape it was clear that Schnabel had made a "radiation symbol" in the centre, with six further symbols situated on a connecting ring surrounding this (the ring was the last element to be laid down). Swish, swish went the crop as Schnabel worked quickly, using his feet as well as his tools to flatten the wheat, treating the crop harshly and roughly and not like a man who was at one with nature.

Inspecting the formation

At last he was finished and left the field some three and half hours after he had

started. I was the first to enter (apart from Peter and Busty who had been in it whilst the construction had been in progress). I went into the largest device on the ring first, an oval supposedly a "garden roller" symbol, and examined the floor pattern which seemed rough, untidy, clumsy and mechanically flattened. Next, in the central radiation symbol, like Holmes and Watson, I examined all around me with great precision and there I noted part of a footprint. I had to use a special lens in order to get a close-up photograph. There is a thin, grey film like covering on immature crop which if disturbed rubs off. (I later asked Schnabel to show me the underneath of his shoes which were trainers with a distinctive ridged pattern. Peter and Busty were also present and I examined the soles of their shoes: theirs had no ridges). I continued my investigation, noting one example of an 'up and under' effect.

A good attempt, but clumsy in comparison with the wondrous 'up and under' interlacing I had seen just the previous day at Goodworth Clatford. What guardian angel had kindly pointed me in that direction enabling me to make such a clear assessment and comparison between its simple shape belying its complexity, and the chaotic bouillabaisse produced by Schnabel? I went through every element of the formation and felt more and more dissatisfied the further I travelled.

Finally I examined the ring linking the six symbols and found it was not joined onto these satellites evenly and was rough, jagged and untidy. What *did* the symbols represent? Quite honestly it was hard to make any sense of them apart from what seemed to be a "UFO" and a garden roller; "What is that?" "What?" "A Grasshopper Warbler!" But to me they were a mixture of a 'something' here, a 'something' there and other 'somethings' everywhere. [Also depicted were a lightning bolt, a smiling devil, and some other device.] It was not even a thing of beauty; there was little artistry (apart from the perspective rendering of the garden roller), no flow to it and all the rotational lay was anticlockwise. I did not enjoy the look of the formation and nor it appeared did other people who all seemed to spend no more than just the bare amount of time necessary to carry out their inspections.

A Schnabel spoof

In making my assessment I had to ask myself by how much was I influenced by the knowledge that it was man made? I still have to say that I believe had I walked into this formation anywhere in the country I would have reached the same conclusion. It simply did not pass the many criteria we now impose before reaching a considered opinion when trying to establish the 'formula' for a genuine crop formation.

"What a waste of time AND to think we have missed the Women's Final at Wimbledon just to see Schnabel make this mess", was a comment I overheard. There even seemed to be a degree of embarrassment among certain observers. How could we ever have been so stupid as to have been taken in by Schnabel? Are we really so gullible?

Not at all. I feel it was one of the most valuable experiments carried out and for those truly interested in researching this phenomenon it is essential to learn more about the diagnostic skills required to distinguish between the real and hoaxed events. If we are not going to continue to waste more valuable time and money taking samples from hoaxed formations we need to learn as much as we can about what features can be hoaxed and which features cannot.

Despite his obvious failure, Schnabel was only too happy to answer questions. Colette Dowell and others quizzed him about

- a) the tangential geometry of the Celtic Necklace, and
- b) what equipment he had used to achieve such exact results?
- c) Had he used a compass? No, he had NOT used a compass, he had not needed

one and any tangential geometry was purely incidental. Also the rich symbolism which most people recognised in one form or another according to their own particular belief systems, was purely incidental.

d) When had he made the formation? He had made it on the August 16th and not the 17th. (Why I wonder, had it not been spotted until the morning of the 17th?)

e) Had he carried a torch with him in order to see what he was doing and to follow his diagram? The moon (full on August 13th) was so bright that he had no need of a torch.

f) Did he plan to incorporate the water trough in his design?

NO, HE "STUMBLED ONTO IT BY MISTAKE". (Maybe the moon had been switched off? And if the water trough was unintentional, I wonder what design takes its place on the original diagram?)

g) How does the angle line up from the dumbbell/female symbol to the symbol on the opposite side, asked Colette? What IS the symbol on the opposite side, replied Schnabel?!!

No matter how long or how hard he thought he COULD NOT REMEMBER THE ORDER IN WHICH THE SYMBOLS WENT.

For a man

- a) who is no slouch intellectually,
- b) who quite contrary to normal habits, goes to the trouble of making not just one but TWO diagrams of the formation and
- c) who then goes to even greater and more elaborate lengths of posting the letter (postmarked Oxford) to himself containing these diagrams
- d) who spent 5 hrs making the formation
- e) who writes about this particular formation in his book.

f) who has a picture of the formation as the photograph on the book's back cover.

Does he really expect us to believe that his memory is so bad that he cannot remember each detail exactly? No, Mr Schnabel, please wink the other eye.

A failure to convince

This was the moment for me when his house of cards fell down around his ears (they had been severely tilted and on a wobble the minute he declined to replicate the Celtic Necklace). At the same time I suddenly realised he was relishing every moment of this question and answer session. HE was the centre of attention, HE was the focal point. That was what clearly mattered and he was enjoying the side stepping, evading and sparring. He was in his element and concern I had for him earlier was evidently entirely misplaced.

He then offered to demonstrate to Grant Wakefield and me, the art of making

grapeshot. Sadly Grant had to leave with Busty and Peter. Was it right for me to go along with this I asked myself? Answer, Yes, all part of our research. So along with Stanley and Sue Morcom, Una Dawood, Jo Holland, Andrew Winn and Mike and Julian (the confessed hoaxers from Northamptonshire) we went back into the field. Schnabel did two demonstrations and then it was my turn. The result--wait for it--an exquisite Pringle Peak! (photographs to prove it). I have to say I felt extremely dizzy. Being small I had to take more steps and go round in more circles than someone bigger. Stanley was next, fair to moderate result, mine was better! Then came the turn of the professional Mike and yes indeed I shall now have to reconsider my assessment of all grapeshot. But where was Stanley to give his opinion of this masterpiece? He had disappeared? No there he was some way off making another grapeshot, perfecting the Morcom Mount. "Stop, Stanley, Stop! Monty soon will have no crop left".

A useful demonstration and whereas 'grapeshot' are quite easy to make in immature crop so long as the conditions are dry, it would NOT be possible to carry out this procedure in wet weather, the crop would be covered in muddy marks, nor would it be possible to enter mature standing crop without leaving some tell-tale trace.

So what lessons did I learn? I learnt that there could be an addictive quality to making 'grapeshot' if genuine research were not your real concern, but most importantly I learnt that it is crucial to realise and understand NOT what CAN be done, but what CANNOT be done, the questions which CAN be answered and the ones which CANNOT and Schnabel's three and half hour effort in the field and the discussion session were an excellent demonstration of the latter two.

Reflections on a circlefaker

What a wonderful case for psychological research. What have the crop circles done to Schnabel? Or have they simply emphasised his existing problems? Maybe his strange behaviour is due to the fact that he will do anything to take his mind off his inherent problems? What sort of childhood trauma has resulted in this desperate need for attention? Did he lack parental love at an early age, did he endure endless sibling rivalry? Is he suffering from an Hippolytus complex? There must be an answer and I suspect it will stem from his early days. Maybe I was correct in my earlier diagnosis and maybe we should feel sorry for Schnabel after all.

It seems to me that there are certain similarities between Schnabel and Doug and Dave. They all three court publicity but when it comes to establishing their claims they run scared and provide absolutely no substantive proof whatsoever. However that does not stop them endlessly insisting that they are prize hoaxers and it amazes me that the public still give them any listening time. Doug and Dave had ample opportunity to prove their skills last summer at *The Cerealogist's* Wycombe Hoaxing Competition sponsored to the tune of £3000 by the German *PM* magazine. If they really had done all the formations which they have claimed, surely they would have won the competition with one hand tied behind their backs? Also *TODAY* newspaper's sales would have once more multiplied as headlines of Doug and Dave's success flashed across the world. And not least, they would have been able to bask again in renewed publicity.

"We never are but by ourselves betrayed,

By frantic boast and foolish word".

To give Schnabel his due, he did turn up and he did make an attempt at 'something', though I do not think he realised (or cared) how badly it would backfire on him.

Since the experiment Schnabel has offered to send Monty the envelope including the diagrams. They will all be tested forensically to establish that they were not tampered with and are of the same period.

He also told me that he would submit a list of formations at the end of the summer, either hoaxed by him or others enabling those of us carrying out expensive

research to eliminate certain formations. For the research into the Human Factor, carried out by Diana Clift and myself, it is of importance to know just how great a part the psychological element may be playing. But, and this is a big BUT, since we have no evidence that Schnabel has made any other than this, in my opinion, vaguely artistic but overall incompetent formation, how will we know whether the list is simply a figment of his fertile imagination or not? How can we believe him when he says he has no wish to undermine serious research?

In conclusion, we all had fun, Schnabel's bluff has been called, I am now a dab hand at the 'Pringle Peak' and most of all, Monty is to be congratulated for masterminding and hosting (despite certain opposition) this experiment which has not only answered many valuable questions and in my opinion, conclusively laid to rest Schnabel's claim to the Celtic Necklace but exposed him once and for all for the trickster that he is. That this experiment has considerably furthered our diagnostic skills and research, there is no doubt.

WELL DONE, MONTY KEEN.

---Lucy Pringle, July 1993.

Editor's postscript

Shortly after Jim Schnabel's demonstration at Montague Keen's farm in Suffolk, he (we understand) created a further replica of the original Charm Bracelet in a wheatfield beside the M4 motorway at Peaks Downs between Lambourn and Swindon. It was found on July 8th. This was roughly laid and the over-elaborate design, which embodied a huge "eye"

surrounded by eight devices on a ring similar to those in the original bracelet, was described by many as unimpressive if not gross. The "eye" was apparently his response to Colette Dowell's parting words at Pentlow: "Hey, Schnabel, God's watching you!" This formation was not a patch on the original. Whether or not permission was obtained to mutilate this wheatfield beside the M4, the hoax was singularly irresponsible and might easily have led to a pile-up on the motorway with resulting injuries or even death.

I never saw the original Charm Bracelet, but I must say that I was always highly suspicious of the inclusion of the water trough in this design. Schnabel's claim that this was included by mistake is preposterous, and if he made this particular formation, one can only think that the trough was intentionally included to serve as an identifier --perhaps for when John Macnish's circle debunking documentary is revealed on TV at the end of this year. This will show low-light camera footage of formations being made and we shall see in due course if these include the Bracelet!

Without wishing to be drawn into the debate on the authenticity or otherwise of the original "Bracelet", I think it should be mentioned that at the time of going to press (Sept 21st) Montague Keen still had not received from Schnabel the promised letter containing the design printed under the stamp. Details of an entirely similar letter with the Charm Bracelet design printed under the stamp are to be disclosed during the *The Cornference* (to be held at the Corn Exchange in Dorchester, October 2nd & 3rd) and this may throw some new light on the origins of this curious story.



Inspecting the "Spooif Necklace". The device nearest the camera is meant to be a garden roller. [Photo: Busty Taylor]

MOVING IN THE VERY BEST CIRCLES

Lois Horowitz tells us about jewellery, T-shirts, and other artefacts inspired by the powerful images of the crop circles.

THERE IS AN aspect of the Crop Formation phenomenon that very little has been written about. I am referring to the way visual artists have "gotten the call". Not being a visual artist myself, I have been delighted to fill my life and home with images of the various formations in precious metals, ceramics, glass, leather and on fabric and paper. I also include pole and aerial photographs timed perfectly for catching our swirled plant friends in the most flattering light and at their best angles. We "croppies" certainly partake generously of the benefits and the power, roaming the countryside in shirts and jewellery displaying our favourite shapes. And I have seen time and time again how even those less smitten are none the less anxious to procure an artist's creation of a special shape to which they are drawn.

So, here's a quick nod to Judy Young and Peter Davenport of *Jupiter Powerwear* who supply those magnificent crop circle T-shirts; to Busty Taylor, aerial photographer extraordinaire; to Patricia Kelly for her ceramics and glasses (in New York); to Ron Russell of *Metafiziks* (in Denver) for his T-shirts; and, new on the scene, Paul Sellers with his *Art of Vulcan* jewellery, fashioned as silver pendant pictograms (he patiently indulged my musings about the 'top' of the Barbury formation!); and also Judy Corbrett of Wales for her beautiful custom diary books. Finally a nod to red haired Jo, who quietly sits (by the *Jupiter Powerwear* table) and draws her luxuriantly coloured cards interpreting the formations, often while in the back of darkened conference rooms. Leonie Starr and I agree that she captures one aspect of the formations that transcends waking consciousness. Millside Forge, of Totnes, market Paul Sellers' pendants and will also soon supply silver pictograms by Isis Line of California. Paul makes steel pictogram wall hangings too, which many will have seen displayed in *The Waggon & Horses*.

Thank you all for enriching our lives with your vision, art and product integrity. The work of some of these artists will be on sale at *The Cereologist's* Cornference.

BOOK REVIEW

THE COUNCIL OF NINE Michael Glickman

THE ONLY PLANET OF
CHOICE - Essential Briefings
from Deep Space.

Compiled by *Phyllis V Schlemmer*
and *Palden Jenkins*.

Gateway Books, £9.95, paperback

PHYLLIS SCHLEMMER HAS experienced profound psychic events since her childhood and was encouraged--indeed trained-- by members of her family who were similarly gifted. Her extraordinary abilities have formed the basis of her life's activities and, around 1970, she was selected to channel the messages of a being called "Tom". Since then she has received communications only from him; it soon became apparent that the information which he offered was of unusual importance.

A group formed around Phyllis Schlemmer to question and respond to Tom; all these meetings were recorded and transcribed.

Palden Jenkins has edited and interpreted a massive volume of information to produce this book. He has worked commendably and successfully to bring these sessions recorded over the best part of a quarter century, to a coherent and readable narrative.

Tom is the spokesman of the Council of Nine, a group of entities charged with overseeing the balance of the Universe. They are making direct contact with humanity now because of their alarm at the state of planet Earth and its inhabitants. We are unaware of either Earth's crucial role in the larger scheme of things or of our own individual ability to significantly improve matters.

A video recording of Tom speaking through Phyllis Schlemmer shows clearly just how physically distressing these sessions must be for her. It also increases one's admiration for Palden Jenkins; the communications, though always astonishingly considerate and polite, are couched in a dense allusive and often barely comprehensible English.

In other times, Phyllis Schlemmer would have been burned as a witch or institutionalised as a mad person. Our response to "channelled" information is the most personal of things. If we accept the veracity of the information, and the integrity of its claimed source, we deny the scientific

structure of our world. And yet, for me, the book presents a convincing hypothesis.

The sheer range of Tom's communications are too great to cover in detail here. Suffice to say that his explanation of the world and our place in it, bears no relation to what we were taught at school! Every page is likely to challenge or shock, and yet chapter by chapter, the reader is drawn in.

I cannot remember when I was last so shaken by a book and this short piece has been among the most difficult which I have had to write. *The Only Planet of Choice* is required reading for anyone with an open and enquiring mind.

M.G.

§§§§§§§§

Of special interest to cerealogists are those passages in *Only Planet of Choice* which touch on the subject of the crop circles. Some extracts from the book where "Tom" is asked (via channel Phyllis Schlemmer) about the crop circles, are as follows :-

Questioner: Can I ask if the current phenomenon we call 'crop circles' that are being formed in England are being created from outside Planet Earth ?

Tom: That is so. When anything takes place within your solar system, it is imprinted and then is manifested on Earth.

Questioner: Could you please explain a bit about the thinking behind the messages that seem to be coded within the circles?

Tom: It is of great importance for humankind to have the understanding of other realities in your universe, of other systems, with the capability to bring these into reality from great extensions of time, of form and of matter. For your humankind to question their origins, their expansion of mind, and the time of now.

....The civilisations are attempting to bring to humankind information concerning other beings, other species, other energy forms, so that humankind may look on this, question it, and then probe into it.

.....Be aware that there are many groups creating them, to distort the real purpose. It is not possible to speak about these at this time. For humankind could not comprehend, for the disbelief would then add no credibility.

Some circles are from civilisations who wish of the most high, and there are others who wish to confuse and add their appendix too. It is timely to create a shaking brain in humankind, to question as you now are questioning. ©Gateway Books

REPORTS & SKETCHES



Circle formation at Skyllberg in Narke.

Circles in Sweden

An outbreak of crop circles in Sweden this summer is summarised in Per Nilsson's report for a Stockholm newspaper.

Is someone trying to fool us, or not? The circles are spreading. This summer several reports have come in about extraordinary formations in Swedish cornfields. In Skyllberg Marten Hokerberg has made two quite curious finds in his fields. One 36.6 metre diameter circle presents a very intricate pattern with diagonal wheelspokes.

These obscure happenings are veiled in mystery but *The Express* wants to reveal the truth about these circles. The corn bends not only because of the wind. Reports of unexplained circles in ordinary worthy Swedish cornfields arrive more and more in our papers. They can no longer be ignored.

Sala in Vastmanland, July 6th: At about 5 a.m. two brothers observed that the sky suddenly changed colour. Shortly afterwards they found two circles in a wheatfield, one of 12 m diameter and one of 6 m.

Harplinge in Halland, July 19th: A woman cycles past a field of rye, while exercising her dog in the morning. She notes nothing unusual. Shortly afterwards she returns past the same field and finds there a perfect circle of 16 metres.

Hoganas in Skane, July 29th: A circle formation, 16 to 18 m diameter, is found

in a field at 6 a.m. by a man passing by.

Skyllberg in Narke, July 30th: Two huge circles are found 800 metres apart. One consists of two concentric rings around an inner circle with an F-shaped appendage (see photo). The outer ring is 96.4 m across. Beside the "F" are two smaller circles of about 7 m diameter. The second circle formation is 36.6 m across and is like a wheel with diagonal spokes.

Ljungby in Halland, July 31st: Farmer Goran Eriksson's neighbour finds a large, somewhat elliptical, circle measuring 16.2 by 14.8 m.

Hoaxes or real? Natural or unnatural? Made by people or space-beings? In about 1980 the first circles were found in southern England. Thirteen years and many hundreds of circles later speculations about their origins are as abundant as the circles themselves.

Now these circles have come to Sweden. Initially many thought this could be the work of extraterrestrials. The theory is supported by the fact they first appeared in England where the local language is easy to learn as all schoolchildren know! But lately the phenomena have spread like rings on the water when a stone is thrown. Reports have come from such distant places as Canada, South America, Japan, Australia, New Zealand, Russia, Switzerland and France. Now Sweden! Nearly everywhere the circles are found in growing crops. In Japan they are in ricefields. The vegetation in the circles shows the corn has been bent in unexplainable ways, sometimes clockwise, sometimes anticlockwise. Many initiates see something symbolic in this, and also that some formations have become intricate figures rather than just plain circles.

In Sweden the military have been given the task of mapping the circles but their interest is fairly cool. It is not of great importance says Arne Gjardman from the FOA. Perhaps it could have been some kind of ball lightning which made the circles.

Hans Alexandersson, a meteorologist from SMHI, says it could be caused by whirlwinds. Neither he nor Gjardman think they are made by space-beings. Clas Svahn from *UFO-Sweden* agrees, saying that it is possibly a natural physical phenomenon. But in England many circles are manmade hoaxes; perhaps the circles at Skyllberg (i.e. the pictograms) are manmade, says Svahn, but elsewhere we have no proof that they were.

Amateur researcher Borje Ekblad, in

Boras, is quite sure about what he has found. He has studied circles in Halland and in Narke. One thing is clear: the circles appear near very ancient historical sites. "Maybe ancient people are trying to tell us something?", he speculates. "I need to study more circles though and I know where", he adds. The explanation can be found south of Boras between Skyllberg and Harplinge, says Ekblad. He sounds as sure as Archimedes once was. "Don't move my circles", said that old Greek. But his circles were made in Sicilian sand and not in substantial Swedish cornfields.

(Contributed by Geoff Gilbertson; translated by Gudrun Pelham)

Pictogram in New York State

Whatever caused the strange design in Helen Pyc's oat field, it sure is the talk of this upstate farming town. The unusual pattern mysteriously appeared this week. That, combined with a report of unidentified objects in the air near the field, have fueled speculation over what caused the design.

"It makes you think; it makes you wonder", Mike Robellard of Iliion said. "Yes, it might have been a UFO", said Cyndie Bailie of West Winfield.

Cars lined both sides of Route 28 for a quarter of a mile about ten miles SE of Utica this week as motorists tried to make sense of the strange design that appeared in the corner of a 20-acre field of ripening oats. People sat on hilltops with cameras and video recorders. Others stood on cars.

They came from Syracuse, Watertown, Albany and many places in between. They came by car, truck and motorcycle. Hundreds of people --many from central New York-- flocked on Sunday to see an oatfield in rural Herkimer County where the circles covered an area about the size of a football field.

On Monday 26 July an unidentified "truck driver from North Carolina" told the *Herkimer Evening Telegram* that he had seen "round cylindrical shapes" in the air near the field. The *Telegram* printed the story and people began driving by to gaze at the pattern. Hundreds started to arrive day after day.

"I lived on a farm for 44 years", said Mrs Helen Pyc of Herkimer. "We've had windstorms, but nothing to make those oats lie so perfect as that. It don't seem possible that a prankster could do that", she said.

The oats lay perfectly flat in precise patterns. Within each circular area the crop lay in a neat concentric clockwise whorl about 25 ft in diameter. Some of

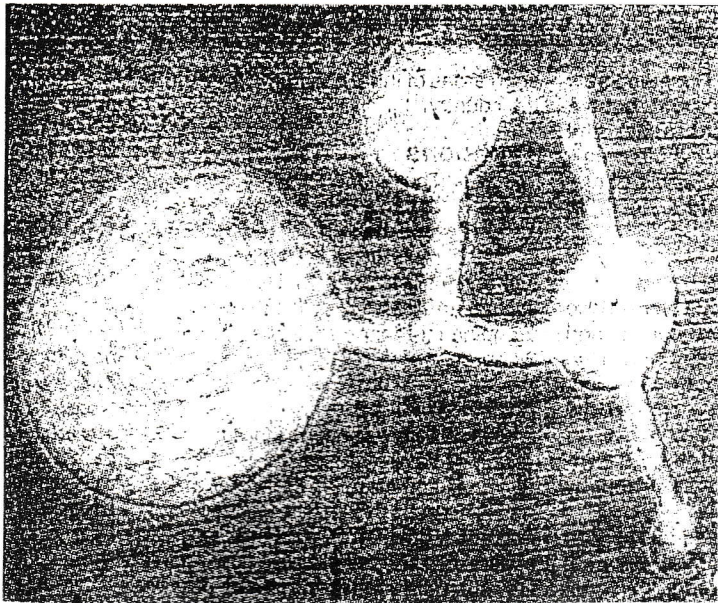

The pictogram in an oatfield in Herkimer County near Utica, N.Y.

those who stopped to see the pattern said it might have been caused by a visitor from space because they see no way that a prankster could have done it.

But some farmers in this Herkimer county community say the patterns were caused by recent violent winds. Neighbour John Kucerak said he saw the oats down a week ago, and said the wind had knocked down some of his own hay as well. The pattern "was definitely the work of the wind", he said.

Others think the patterns are the work of pranksters. "I think there's somebody looking out of the window of that barn right now laughing his pants off", said Paula Macisco of Frankfort, N.Y.

(Reports from The Times Herald Record, Rochester, N.Y.)

New Zealand circles

Dunedin, South Island

UFO landing sites, moa mating circles or fairy rings? Locals in Ranfurly are at a loss to explain strange circles, up to 15 metres in diameter, which have appeared in their district over the last three weeks. While the rest of New Zealand struggles to cope with the possible re-emergence of the extinct moa, the Ranfurly community now has its own mystery to deal with, and so far the answers are not forthcoming.

Those who have viewed the circles in the dry and barren Maniototo landscape from land and air described the phenomenon as weird. Lying on the southern face of a hill between Ranfurly and Wedderburn, the circles range from five to fifteen metres in diameter and are visible from State Highway 85.

While some appear to form a pattern with symbolic meaning in their proximity to each other, others seem to have drifted aimlessly across the hillside before touching down.

The entire community was awash with talk about the circles, according to a local publican, Mr David Weyer. So far the best explanation has been the

UFO landing site, although he hastened to add that no spacecraft had been seen in the area -- not yet at any rate.

Other explanations have included moa grazing rings, or circles formed by moas stomping round during their mating ritual.

The owner of the property concerned, Mr Bill Carson, said the circles had appeared in an area which he had planted out with trees about four years ago. The circles only slightly resembled fairy rings but, strangely, he cannot recall mushrooms ever growing there.

The furrows and circles show a strong growth of exotic grasses, evidence maybe, of sophisticated soil fertility techniques from outer space!

Scientists could not be reached for comment last night but indications are that they are likely to dampen fertile imaginations with the fungus ring theory.

(From Press, Christchurch, N.Z., Feb '93)

Operation Maggie

Our friend Erik Beckjord has been up to his tricks again. His *Operation Maggie* marked a further attempt at communication with hypothetical extraterrestrials. Alleged claims of hoaxing notwithstanding, readers of *The Cerealogist* must make what they will of the following episode.

On August 12th on Hackpen Hill, near Broad Hinton, Erik Beckjord and Joan De Neve of Los Angeles created a message cut in grass using an industrial mower.

The message was designed as an "English lesson for aliens" to facilitate the transition from circles symbolism to plain English:-

MAN = matchstick man symbol

HOUSE = basic house symbol

WATER = wavy lines symbol

LOVE = heart symbol

Each word was over 25 ft in height. It was near here in 1991 that Erik had written the words **TALK TO US** in a field which were claimed to have elicited as a response the Milk Hill Script.

What response was there to his 1993 effort? Although one cannot be sure of any connection, a fresh pictogram appeared near Silbury Hill on Friday, August 13th. This bore an uncanny resemblance to the universal 'Disabled' symbol which represents a person (or matchstick man) in a wheelchair. The farmer was not amused by what he took to be yet another hoax and destroyed the formation soon afterwards.

A further 'Disabled' Symbol pictogram, this time facing to the right rather than left, appeared the next day between Lurkeley Hill and West Overton (see photo).

What does Erik make of this 'response'? "Man is handicapped, man is in trouble, man must reform" is the message, he says. (We knew that anyway, didn't we?) His team hopes to return next year to pursue this conversation. During 1993 they saw and videotaped two red UFOs. Were these viewing crop circles, or... making them?



"Disabled symbol" pictogram found near West Overton not long after Operation Maggie

NEW SWIRLED ORDER

Michael Glickman



THREE YEARS AGO every single crop circle, each tiny grapeshot, was greeted with pleasure. None of us knew what was going on and, certainly, nobody had any method of determining the origin of this phenomenon. We loved it and we trusted it.

This year every single event has tended to be treated with suspicion. We still do not know what is going on and, certainly, we are no closer to determining the cause of the circles. Has the tribe lost its nerve?

Our certainties, on both occasions, are an indication more of our feelings than anything else. The evidence we have been receiving has not changed very much. The mystery remains the same. The only shift has been our arrogant ability to make sweeping judgements.

We have to accept that many Croppies are gullible and starry-eyed optimists. Hoaxers, however, are - by definition - deceivers!

All circles are part of the phenomenon. When I see a video of a particular formation being constructed by humans, I will have a reason to modify my opinion.

A group of kids plays happily in the park. A child comes by, watches them and joins in. A second child passes by, decides the game is not for him and walks away. A third child sees them playing and realises that he can join them and ruin their game!

We all know the Category 3 kid, the spoilsport, from our own childhood. At the time we hated him. It is clear in retrospect that these were the unhappiest of kids. Children so wretched that they took pleasure in destroying the games - and the dreams - of others.

By and large, they grow up to be gentle and tolerant people. But sometimes they become debunkers, threatened by change, cynical about the new and the unorthodox, censorious of the open-minded and terrified by those whose vision and imagination dwarf their own. They take a smug delight in kicking over sandcastles.

Think about it, Doug and Dave, Schnabel and Irving and every sad and driven Wessex Sceptic!

The Nomenclature Sub-Committee met to discuss the word "Croppie" recently. There had been a complaint from a woman member complaining that this was a male noun and demanding that, in view of the strong female presence among the

Cerealogically Intrigued, a feminine designation should be established. Michael Green, always the classicist, suggested "Croppa". This was at first deemed satisfactory until a member pointed out the risk of misinterpretation, as in "coming a Croppa!" After much discussion "Cropette" was adopted.

The Ways, Means and Byelaws Working Group considered the question of wheelchair access to the circles. It was reported that the National Farmers Union had happily accepted the requirement to increase the width of all tramlines to a minimum of 850 mm and the matter was now before the EEC Agricultural Group. [This may, or may not, be connected with the appearance during August of two pictograms resembling the 'Disabled' symbol, showing a person in a wheelchair, near Silbury Hill and near West Overton. See photo p 21. -Ed] It was confirmed that, as from the start of next season, circles in fields without wider tramlines would be designated a "Hoax". A point of order reminded the Working Group that under the Glickmann (1992) Amendment, this word could not be used. The phrase "man-made cerealogical event" was suggested to the immediate anger from the Woman's Agriglyph Alliance representative. It was finally agreed that "Crop marking by human agency, female or male" was acceptable.

The Cultural and Social Committee was given a letter outlining the problems caused by the limited availability of Creches in the Circles. The Group unanimously accepted a motion to put in place fully-staffed facilities in every formally-accredited crop event within 24 hours of its occurrence. A motion to similarly establish First Aid posts was felt to be outside the Group's remit and was forwarded by the Chairman to the Interim Health and Safety Sub-Committee of the Engineering, Surveying and Calibration Working Party.

As readers will know, John Michell, Richard Adams and Christine Rhone, the team that created and ran *The Cerealogist* (and the Cornferences) for the last three years have stepped down and handed responsibility to John Haddington and George Wingfield.

While I have no doubt that the magazine is in the best possible hands, I know that

both John and George are aware that the previous group is a hard act to follow! The last three years have been a delight. *The Cerealogist* has taken the high ground. John, Richard and Christine are to be congratulated in having consistently produced an enquiring, informed and good-looking journal. It has been a privilege (and fun) to be on the team.

I look forward to the next three years.

CORNELIA

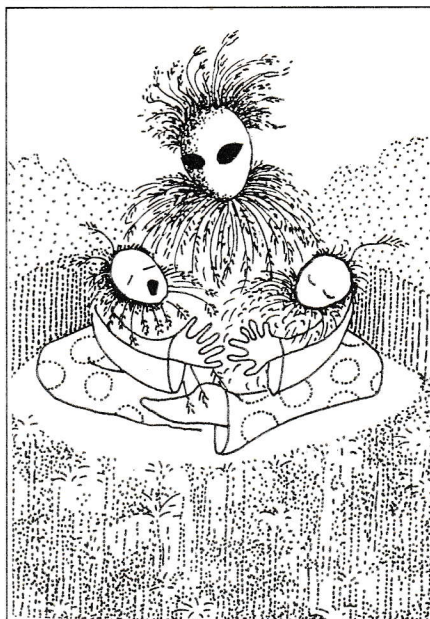

CHRISTINE RHONE

My new generation of cerealogists, into all kinds of mischief Robin Goodfellow's kids, I think ..



PHENOMENAL BOOKS!

Crop Circles - UFOs - Earth Mysteries - Mind - Body - Spirit

Send 6x1st-class stamps for our mail order catalogue (6000 titles)

THE INNER BOOKSHOP
111 MAGDALEN ROAD, OXFORD OX4 1RQ

LETTERS

The Skunk et al.

From Mr George Wingfield

What utter rubbish Peter Rendall writes in his letter published in the last issue! I fear that I must take the unusual step of writing to the magazine which I now edit in order to answer this crude attempt to misrepresent me.

If he cares to actually *read* my article in *Cerealogist* #8, "Snake, Weasel and Spiderman", he will find there is no claim by me that the circlefakers are "Government Agents", MI5, MI6, "spies", etc., or anything else that he would have you believe that I believe. That is merely his fantasy. What I wrote about was a determined and malicious campaign by a number of people to set up and discredit leading researchers by faking considerable numbers of circles and pictograms. Who said these people were "spies"?

No one has sought to deny that there was such a campaign (which was perfectly obvious) and "Snake" and "Spiderman" have since confirmed much of what I charged them with, and identified themselves in an article in *Fortean Times*. If Peter Rendall wishes to deny that he is a circlefaker, that's fine with me, but if he arrives early at a new formation, driving up with Spiderman, who subsequently claims to have made it, it seems fairly obvious that he is a party to the deception and to this campaign. And it should not be forgotten that circlefaking without the farmer's permission constitutes criminal damage.

Even if CERES was only *aware* of such activities, it should have given such information to the police. Did Rendall ever tell the police what his friends were up to? I have been exposing circle hoaxing for well over a year now --such as at the Salisbury Conference in August 1992--, yet when information was given to the police then, the author of a recent book on the circles sees fit to make the grotesque allegation that I had done this to "prevent Irving from exposing his hoaxes and embarrassing Wingfield and the CCCS". This shows the complete disregard for the truth these people have.

Government interest in the circles, which I did mention, remains unpublished but it is certainly there and we have seen quite sufficient proof of it. Circlefaking in itself is a conspiracy to deceive but that does not make every circlefaker a "spy"! However the justification offered by the

aforementioned author that his circlefaking was solely for the sake of "cerealogical art" is nothing but the purest hypocrisy.

Peter Rendall has attempted to misrepresent me before by suggesting that a belief in the reality of the UFO phenomenon (other than the strange notion UFOs were "plasma vortices") meant that I must believe in little green men flying about in spaceships. No, Peter, that's not what I ever said, nor did I say you were a spy, so please don't always attempt to put words in my mouth.

GEORGE WINGFIELD

Hearne House, North Wootton,
Shepton Mallet, Somerset

Where to see a circle?

From Ms Eva Bjarlund

I am one of your devoted subscribers in Sweden but I must disappoint you for I have never spoken to a dolphin, let alone been one in a previous life... I am just plain fascinated by the Crop Circles (that have not appeared here in Sweden to my knowledge, or are we too rational to pay any attention to such a phenomenon?) and at the beginning of August I will spend some time in England and, of course, I'd like to see more of this phenomenon.

Silly as my questions may be, I have to ask them:

Where to start, if there is a chance to see a crop circle? Is August too late? Do you have a hot line where I can get information?

I am looking forward to a reply with the greatest confidence!

EVA BJARLUND

Sjomansgatan 20 D, 413 15 Goteborg

You don't have to come to Britain to see circles. This year there have been several in Sweden. One at Harplinge in Halland was not too far from Goteborg (see p 21). In England August is almost too late, since the harvest starts then but you will still find circles; harvesting is rather later in the north of the country and circles in, say, Yorkshire can still be found when those in the south have all been harvested. The CCCS hot-line telephone no. for circles information is 0726-832367.

Reactions to the hoax dilemma

From Mr Laurence Newnam

As a relative newcomer to the crop circles, I thought I'd offer my perspective on the current round of controversies if you'll indulge me.

I attended the Glastonbury Symposium last year, and I was able to visit several formations. I've read everything I can get my hands on about crop circles, and I've

heard George Wingfield lecture in the U.S. on two occasions.

My initial reaction to the writers and researchers who contributed to books like *The Crop Circle Enigma* and *Crop Circles: Harbingers of World Change* is one of admiration and respect for the breadth of knowledge and vision displayed. My esteem for all of you continues the more I learn about the earth mysteries and the sacred sites of Wessex. People like George Wingfield, Colin Andrews and Busty Taylor have exhibited great courage and dedication in building a framework of research, collation and distribution for the world at large. All the researchers, dowsers, writers and psychics that I've read seen or heard are a collective treasurehouse of knowledge and experience. Andrews, Noyes, Green, Delgado, Pringle, Haddington, Roy, Davies, Bartholomew, Kingston, Jenkins, Glickman, and Collins have all made great contributions with their work. I've left out many other dedicated and insightful people who have continued to build upon a foundation established by John Michell and others.

But why, then, are you all becoming so blind to yourselves? Why are you so hard on each other? Take the hoaxing controversies which have come to dominate the discussions. Yes, Michael Glickman is right in saying that hoaxing is unimportant, ultimately, unless someone can prove that 100% of all formations through history have been hoaxed.

But why be so hard on George Wingfield for his anger? Wouldn't most of us be equally infuriated if we found ourselves having to divert precious energy away from productive research into putting up defensive shields against trickery and deceit specifically intended to discredit oneself? Wingfield has every right to be paranoid, and he has the right to choose his own battles. The man deserves a respite from attack. Perhaps I'm naive, but I believe that George would be the first to admit that the phenomena were all a great hoax if the objective evidence finally pointed in that direction. His ethical and intellectual gyroscope appears to be just fine from everything I've seen or heard. (Or am I just not privileged to the *inside scoop*?)

Why do you need a scorecard to keep track of who is in favor and who is on the "outs"? Why do I get the feeling when I talk to some well-connected people, that UFOs and Orgone theories should be swept under the rug? In other conversations, among the MUFON crowd, there is no room but to discuss anything but UFOs. From where I sit, I'm glad to hear what all of you have say, but I wish you would spend more time saying what you believe

as opposed to who you don't believe.

Those of you who live in or close to Wessex are quite blessed to be living where you are during these extraordinary times. For the most part, you have all recognise it and have diligently and graciously gone about the task of sharing information with your friends in other countries. Lately, though, your own infighting is beginning to wear thin with those of us who depend on you and your excellent work.

May I suggest that you all take a second and step back from the picture. You have all done an excellent job of examining this phenomenon from every possible angle. We appreciate your frustrations. But we also appreciate your successes and we wish that you would get back to the job at hand. Those of us who can't be with you in the fields are depending on your reports. Whatever you have to say, we'll be listening.

LAURENCE NEWNAM

P O Box 552, Arlington, VA 22216, USA

A Swiss pictogram

From Mme Michele Burdet

What may have been Switzerland's first cereal pictogram appeared in early July in a wheatfield between Bern and Neuchatel. The accompanying photograph was published in *Der Bund* (Bern) with the caption "Pictogram in Grainfield -- The Work of Extraterrestrials?"

The formation was visible only to passengers on the secondary rail line linking those two cities, as trains passed over a viaduct spanning the Saane (or Sarine) river. The dark bar in the photo is the railing of the viaduct. The formation was not visible from any road or hill, only from the railroad viaduct, and therefore only fleetingly for alert passengers. To visit the pictogram, one had to descend at Guemmenen and then walk a considerable distance on rural lanes. The nearest farmhouse is about 1 km. away.

On July 22nd my dowsing companion Violette Buhlmann of Bern visited the site. It was evident that some "editing" had occurred with two spurs being added sometime after July 17th.

Not only were the additions somewhat sloppy in execution, but a study of vibrational levels clearly suggests that someone had added hoax features to an apparently valid formation. Violette found extremely high vibrational rates (nearly 5 times normal) in the exact centres of the main ring and of the end "bulb" of the lower appendage. The main ring registered nearly 3 times the normal rate around its circumference. By contrast, the later additions produced vibrational values just



Piktogramm im Getreidefeld Das Werk von Ausserirdischen?

The crop formation near Guemmenen.

slightly above normal. All vibrational readings were made using the Bovis technique, widely used in continental radiesthesia.

Other analytical techniques employed, most especially the calibrated Lecher antenna, indicate that two of the centres of high vibrations are blind springs as defined by Fidler and Underwood. Her data deny anything of a spiritual or religious significance to the site, although they do suggest cosmic and magnetic origins.

Having worked with Violette at a number of spiritual, megalithic and mountain-top sites, I have great confidence in her data. In comparing notes after surveying the same site simultaneously, but separately, we usually come up with almost identical readings. She is an expert, experienced geobiologist, so I transmit her findings to you with confidence.

July was frequently stormy, with a great deal of rain and wind, making it very difficult for the farmers to harvest winter wheat. On July 30th it could be seen from passing trains that the field had finally been harvested. And one could also observe that the farmer had also attempted to extirpate whatever "magnetic force" remained in the ground by vigorous scarifying in roughly the pictogram's pattern. However Violette reports his ploughing was well to the side of the pattern's position and one could still make out the outline of the pictogram.

Thank you very much for having launched *The Cereologist*, for having imbued it with a high standard of cover-

age, and for having found responsible successors. It would be very interesting if an issue in the near future could deal comprehensively with whatever may have been happening (if anything) in the vast cereal regions of the United States.

MICHELE BURDET

Chalet la Palette, C.P.33, 1885 Chesieres,
Switzerland

Talk to us ...

From Mr Erik Beckjord

In Bigfoot research there has long been controversy over tracks and what they mean. We found long ago that the best route was to waste as little time on tracks and aim to watch for and see Bigfoot whenever possible.

With UFO sightings claims count for little. Photographs and films are what count.

Now with crop circles, to avoid the endless drain of hoax claims, I suggest that we cease giving so much attention to individual circles and concentrate on (1) talking back and forth, using the fields as a blackboard, and (2) trying to film circles being made and also UFOs/luminosities that fly near them.

Let us stop all the arguing about which circles are real. Some are -let it be left at that- and let's go on with steps (1) and (2) above.

ERIK BECKJORD

P O Box 2534, Malibu, CA 90265, USA

A magick cucumber

From Mr Bernhard Hauser

I'd really like to know what's happened in the cornfields this summer and hope that the *Cereologist* will be out soon. Loads of hoaxes to be sure!

By-the-by: I've made a nice little discovery connecting the Barbury Castle formation which might have been missed by anyone else up to now. It's really amusing. So please..

Go to your greengrocer, buy a cucumber and take it home. Good! Wait until evening, go to the dinner table and light a candle. Good again! Now take a knife and cut your cucumber at any place you like. What do you see in the profile?? BARBURY CASTLE !!! Do it again, and again -the result's always the same.

Now, wasn't that a discovery worth telling?! Well, it's not *exactly* what we've seen in the field, but with a little imaginative power it comes quite close to it!

With best wishes for further studies.

BERNHARD HAUSER

Sommerweg 16, 88048 Friedrichshafen,
Germany

Californian circle conundrum

From Mr D.T. Munda

I have had six close-up UFO sightings in my life so I know something radical is happening here. This has perhaps been inspirational to my book *Zen Munchkins* (Charles E Tuttle Co. of Boston, Mass., 1991). I also have some close friends who in 1975 had a very interesting experience.

The three of them drove up the coast from Los Angeles for several hours to go hiking in a very beautiful park. They got there early and started walking up the long trail towards a more mountainous area.

They passed several men coming down the trail who seemed to my friends strangely familiar. It was quite early in the morning and these men looked very fresh but didn't seem to be carrying much in the way of camping gear.

As my friends walked further up the trail they came across a large circle in high grass just off the trail. The grass was swirled in a very dramatic way from the center outward.

I never put it together until a few years ago. Then I understood that they had seen a Crop Circle. I also believe that they had said hello on that trail to several beings that had connections to whatever created that Circle.

D.T. MUNDA

7903 18th Ave. W, Bradenton, FL 34209

A Mowing Devil ?

From Mr Mark Briggs

In May 1991, this formation appeared in my lawn in upstate New York. The design appeared, unobserved, within 15 minutes, and its construction seemed to have been associated with a whine which has been described as being uncannily like a gasoline motor. Amazingly, the heads of the grass plants were lopped off uniformly at precisely 2.35 in. from the ground. The

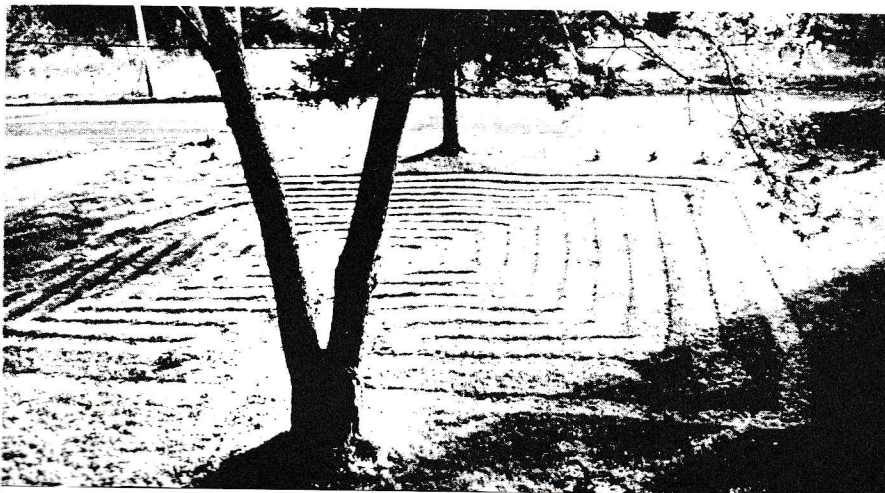

Mr Mark Briggs' lawn in upstate New York

remaining plants were whorled in a clockwise pattern, as if tremendous rotary force had been employed. The swath of this force was a uniform 21 in. Severed tops of the grass plants seemed to have been chaotically thrust off to the right of the apparent direction of travel of the formation-making instrument, or beam, but there was a single long bead of heaped grass, as if they had been thrust at high speed out of a chute onto the ground.

The formation has a single entry with a unicursal path leading only to the center. The Circle Makers apparently began in the center, moved anticlockwise, changing direction at the end of each swath, emerging from the formation at the fifth path from the outside. These sudden changes of direction (varying from 90 to 180 deg.) form a microcosm, mimicking the twisting and turnings of our everyday lives - thus making a subtle philosophical statement.

Furthermore you will note that some of the paths are not straight, and the "walls" are not all of uniform thickness indicating a wry comment by the Circle Makers on the fundamental imperfection of life itself.

By the way, I think *The Cereologist* should change its name to *The Journal of Unexplained Ground Markings*, thereby expanding its market and insuring its survival, should the crop phenomena cease. I am a loyal subscriber, and I appreciate the service that *The Cereologist* is.

MARK BRIGGS

1134 Nottingham Rd, Jamesville NY13078

More Ishtar nonsense

From "Ishtar"

Ishtar speaks again

Ishtar is not to be associated with CREEP. Ishtar is angry. Ishtar leads "CRAWL" - Campaign to Reveal All Wingfield's Lies.

Ishtar knows all --Ishtar has been in your house when you're not home --what

are the strange eye-bolts in your back room ceiling?

Ishtar has moved the Michael line --how dare you move it from going through your house!

Ishtar knows all --careful who you speak to -- MI5 is rising; they know all about your friends in high places.

I know who has made all the circles -- look from within. MBF is active again -- suggest you ask closer to home. --Wait-- can I see them in your rubbish bags? Can I see them at your neighbour's house?

Ishtar knows all. Do not anger him again. Now you run *The Cereologist* you'd better print this letter --they all must know who's helping you. Remember Ishtar knows all.

Above all Ishtar knows Pan, from the very night Christ was born -circles within circles - the star of Bethlehem.

The channel is fading, cannot continue, help, help, help,help...

Oh, mighty Ishtar --what else can I do to appease you?

No! Stop the mutilations and the abductions -they (humans) are close to an answer -- they have seen the lights in the skies and the marks in the corn. Release Oberon now. Sanctify the Sunrise line, for those who domain upon this line are in fear of their sanity.

ANONYMOUS

Talking of sanity, I suggest that the author of this letter, a well known circlefaker (who evidently creeps around my backyard when I'm not home, peering in the windows), seeks urgent psychiatric help. This correspondence is now closed. --Ed.

Catalyst Circles

From Ms Kerry Blower

We appear every summer in the golden cereal fields.

How do we appear there ?

That's a secret we'll not yield

We silent patterns listen

To every spoken word.

Are we hoax, or a UFO ? Is that sound a tiny bird ?

Our job is very simple, 'tis to join all man as one.

And not so far off in the distance our job is nearly done.

We watch man come together even if only for a while.

Your soul receives our message, and CATALYST circles smile.

KERRY BLOWER

10 Glaslyn Court, Croesyceiliog, Cwmbran, Gwent NP44 2JE

GLASTONBURY SYMPOSIUM

Ray Cox reviews 'Investigating Crop Circles' 1993

ROLAND PARGETER'S THIRD annual gathering at the Assembly Rooms in Glastonbury might well have taken place amidst apprehension and languor. It had, after all, been until then a somewhat sad and sorry season out in the cropfields with a profusion of spurious and often weak and uninteresting formations. Even Colin Andrews and George Wingfield, with their always compelling presentations, chose to ignore them. George did present some slides of anomalous light phenomena, an area which promises increasing interest and significance.

Yet it was a successful conference, often positive and uplifting. I was not surprised by this as I have felt for some time that the crop circle community has suffered, and passed through a crisis, following the almost crusading years of 1990 and 1991, and then the doubt and confusion subsequent to Doug & Dave, and the 1992 season. The only solution was a catharsis, and this is what has been experienced, a new feeling, a calmness, a turning to the heart/mind/consciousness element. This was intuitively present with many speakers, who retained previous years' standards and interests, but with some new and intriguing developments.

The coach tour to the Avebury area had coincided with one of Andrew Collins' orgone experiments and his talk at the symposium offered an initial outline of a potentially important development. There were photos of bioforms apparently manifested by the meditative processes, themselves measurable. The aims of the study intend to show whether biologically related energy (Wilhelm Reich's orgone) has a direct relationship with ancient ritual landscapes; whether it is responsible for producing condensed masses of such energy; also to see if bioforms possess independent intelligence. The recording of the presence of such a phenomenon seems positive, and, although the connection with crop circles seems far from determined, Andrew Collins and his team have made a good start and will continue in 1994.

On an even more down-to-earth venture there was Dr Steven Greer, director of CSETI, a collection of groups whose aim is to communicate and respond to ETs visiting this planet. He proposes that there is strong evidence for the existence of such ETs and their spacecraft and suggests we must assume their motives and ultimate intentions are peaceful. Humans can take the initiative in inducing friendly and cooperative contact. Steven Greer reviewed

in detail the occurrence, well documented, of the near approach of a 'structured craft' near Woodborough on July 27th 1992, and also a similar encounter in a remote part of Mexico. Here again meditation was key.

Contributory talks covering actual crop circle studies were provided by Lucy Pringle, Montague Keen and Chad Deetken. Lucy talked about the anomalous physiological and psychological effects experienced in crop circles, outlining specific examples. Montague Keen reviewed Project Argus' 1992 study of crop and soil samples. The report was thorough whilst the results were somewhat negative, or at any rate inconclusive. Some interesting findings were made in the area of electromagnetism and it was felt that this is the area where future scientific study should lie. Chad Deetken gave a survey of the Canadian circles. His presentation of the peculiarities and features which he'd found were received with particular interest.

The balance of the symposium was provided by the more spiritual and esoteric approach of Michael Glickman, Isabelle Kingston, Palden Jenkins and Stanley Messenger. Michael entertained his audience with a perceptive and intuitive presentation, deceptively slight, with the emphasis on distinguishing between the personal as against corporate element. Isabelle talked of the living landscapes used by the ancients, places of power, the significance of the plant world and the sky, and the importance of people in the circles phenomenon. Whatever their origin, the symbolic aspects of the formations present images which are entering peoples' subconscious and the effect is at the heart level. This theme was taken up by Stanley

whose background is the study of Rudolph Steiner's anthroposophy. His pre-occupation with the circles concerns whether they are an indication of the investment by transcendent forces and beings in bringing human consciousness to new realities. The circles can be places for meditative techniques and they have been used in his own channeling work. Palden then gave a fluent discourse on the attributes of ETs (whom we should not term aliens) and their intentions from an evolutionary perspective. Human beings must change their ways to advance in consciousnesses to meet them.

Last came Colette Dowell and John Martineau, both dazzling in their dexterity and sleight of hand. Colette, a practising naturopath physician, described her circles research based on the fascinating geometric ratios correlated with measurements of Earth, Sun Moon, etc. John Martineau also engaged in geometric analysis but with a series of computer generated diagrams that included display of an amazing correspondence between the Charm Bracelet's geometry and Michael Dames' plan of Silbury Hill. His work in revealing this and other marked and apparently coincidental features brought, throughout his outline, spontaneous acclaim.

In ancient Greece, a symposium was a party with music and, as usual at Glastonbury, the weekend included music. Cellist Emily Burridge gave us that haunting crop circle inspired music so characteristic of her. The newly formed Avalonian Free State Choir sang, among other items, and unaccompanied, folk songs from Georgia, Bulgaria and Corsica.

In all the symposium was, as the introductory note suggested, "a chance to start again, clean and simple and open, content to be part of a growth process which we can neither hurry nor stop."

Here at least, the jeers of the 'opposition' were left far behind.

*We have not failed,
While fools busy themselves with trivialities in the fields
Aping the majesty of bygone days, we move on.
Leave them to their fruitless endeavours of crop carving.
Bathe in the True Light we know will one day shine in England's fields.
The sacred direction is North,
So turn your gaze to those clear northern skies.
Wait for the brilliance that will surpass by far the past events.
Coloured orbs descend to Earth and fly above the heads of men
In diamonds, squares and boomerangs of flashing light. Spiral radiances
Once glimpsed upon an Axminster carpet before a Cheshire hearth,
Signal from the region of the Plough, as heads turned upwards in disbelief
Follow the phosphorescent trail of the Great Green Spear
That fades from view on its way to the East.
A single note sounds from the looming Ridgeway, like a distant call to gather hounds,
And shadows move upon the turf, the click of iron shoes on flint, a murmur of voices,
The Hunt is on.*

HADDINGTON

WHY BUILD YOUR HOUSE ON CORN?



Bored with your patio?
Wanting something different for the garden?
Eager for new influences in your life?

STONEHEADS

STONE CIRCLE BUILDERS FOR MILLENNIA

Stone circles, stone rows and dolmens built to order.
Astronomically, Geometrically and Geomantically balanced.

The Walkmill, Discoed, Presteigne, Powys LD8 2NT.
Tel/Fax: (05476) 251

PERMANENCE IS EXCELLENCE

Stone Circles can take many years to design. Please order well in advance. All jobs considered.

Advertising in The Cerealogist

Advertising rates are available on request from :-

The Cerealogist
Hearne House
North Wootton
Shepton Mallet
Somerset BA4 4HW.

Tel or Fax : 0749 890257

Crop Circle MYSTERIES BOARD GAME

INCLUDES P&P

ORDER FORM

(Please tick boxes as appropriate)

I would like to receive:

- Advanced £26
 For ages 7 to 70 £17

_____ Please allow 28 days for delivery _____

join the **UK HUNT**
THE BOARD GAME WITH A
TREASURE HUNT

ADVANCED Game only

PAYMENT by postal order.

Make payable to:

G. T. Vernon
16 Beggarswell Close
St Pauls
Bristol BS2 9JH

signed Merlin

CROPCRAFT

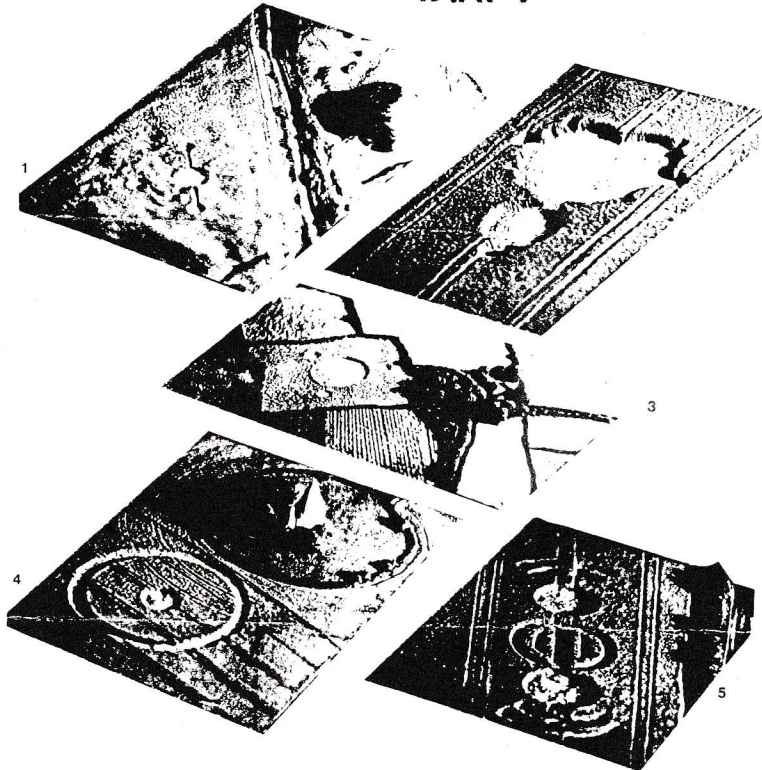

EACH CROP CIRCLE DESIGN IS HAND PAINTED AND MEASURES 5.5" X 4.5"

PRICE PER MODEL: £9.95 PLUS £2.50 P&P

CHEQUES MADE PAYABLE TO: P.D. MALLOWES

AVAILABLE FROM:

CROPCRAFT: 123 HAYES CHASE, WEST WICKHAM, KENT. BR4 0HY
☐ (081) 777 2348 OR (081) 462 8832

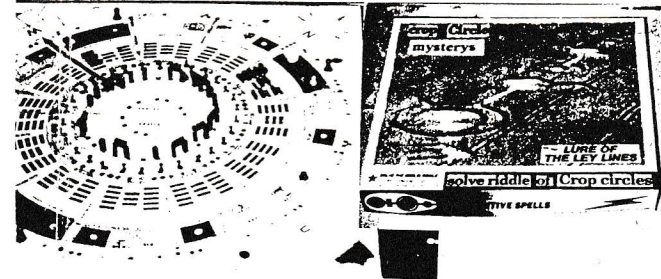

COLLECTOR'S SLIP CASE

PRESERVE YOUR COPIES OF THE MAGAZINE AS A
COMPLETE AND ON-GOING ARCHIVE OF THE CROP
CIRCLE PHENOMENON.

To obtain easy access to the only complete, season-by-season record of the crop circle phenomenon in all its aspects, it is best to preserve your copies of *The Cerealogist* in the special collector's clip case. This useful item is bound in plum-coloured material with gold lettering on the spine, and looks good on the library shelf. You can order it from *The*

Cerealogist, 20 Paul Street,
Frome, Somerset BA11 1DX,
sending £8.90 or \$19. For c.c.

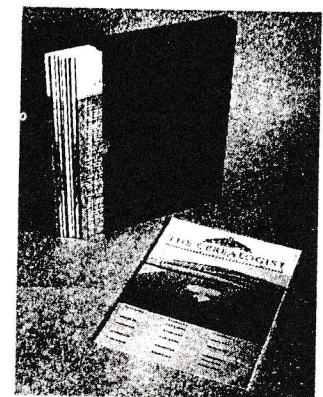

orders call 0373 451777 or
see subscription form
inside.



The Only Planet of Choice

From the *Council of Nine*,
through Phyllis Schlemmer
compiled by Palden Jenkins

People will try to borrow your copy before you've even read it!

"Channelled material can be such a minefield -
it's good to come across something so obviously genuine"

(Christopher Hansford, journalist & critic)

"Everything you wanted to know about the Universe,
but didn't know who to ask"

(Kindred Spirit Magazine)

"There is food for thought on nearly every page"

(K Jonsen, Norway)

*Essential reading for cereologists.
One of many life-changing books from Gateway.*

In all good bookshops.
We also do mail order.
Special discounts for networkers.

Gateway Books
The Hollies, Wellow, Bath BA2 8QJ, U K.
Phone 0225-835 127; fax 0225-840 012.

Gothic Image Publications

would like to welcome
George Wingfield as new Editor of
The Cereologist
and wish him every success
for the future

Don't forget - if you are looking for
"books that make you think"
- ask for Gothic Image Publications.
Available from all good bookshops
or write to us for our new catalogue:

Gothic Image Publications
7 High Street • Glastonbury
Somerset BA6 9DP
Telephone: 0458 831453

GOthic IMAGE

P U B L I C A T I O N S

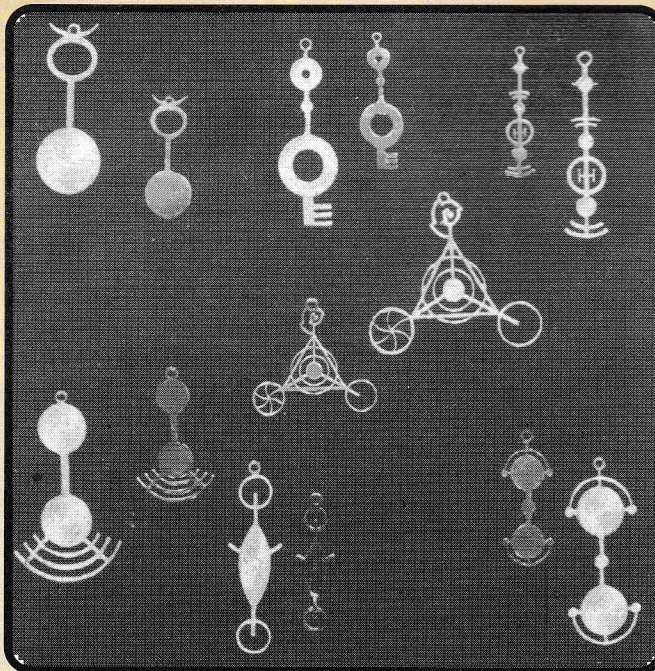

Designs (left to right)

Top row : Pendulum, Key, Pictogram
Centre row : Golden Tripod
Lower row : Phoenix, Whale, Dumb Bell

Examples are shown smaller than actual size.
Sizes are approximately: Small - 35mm Large - 50mm

Symbols in the corn

*Unique high quality jewellery
inspired by crop circle formations*

Handcrafted in sterling silver

All designs are available as pendants, earrings and brooches in
small and large sizes with a choice of polished or swirl patterned
finish.

Pendant	small	£11.99	large	£12.99
Brooch	small	n/a	large	£12.99
Earring (pr.)	small	£12.99	large	£14.99

Earrings include top quality sterling silver hooks. pendants are
complete with strong 18" sterling silver chains. All include
delivery by first class post.

To order simply send cheques/postal orders/Access/Visa details to
Millside Forge Limited at the address below. Phone orders by
credit card are welcome. All orders are dispatched promptly.

Millside Forge

Foxhole Dartington Totnes TQ9 6EB
Phone: 0803 868100 Fax: 0803 868400

TRADE INQUIRIES WELCOME